



BLUESTAR® 30" ELECTRIC WALL OVEN SERIES (24" & 36" COMING SOON)

Introducing the new BlueStar® Electric Wall Oven – the power, performance and quality of a BlueStar® - is now available in electric. Professional-level features combined with heavy-duty construction and unparalleled customization options make this oven the perfect addition to any chef's kitchen.



Professional Performance

The powerful 2,500 watt bake element and the intense 5,000 watt infrared broiler provide restaurant-quality results every time. The 1,500 watt heat assist element in the rear of the cavity means faster preheating & less time waiting.



12 Cooking Modes with Convection

Intuitive touch screen control panel with 12 cooking modes, including Bake, Convection Bake, Roast, Convection Roast, Broil, StoneBake™, Proof and Sabbath, provides unmatched cooking options. Optional convection fan can be used in most modes to provide optimal heat circulation and perfect results.



Integrated Bake Stone

In StoneBake™ mode, create perfectly crisp breads and pizzas at home. The built-in, artisan baking stone is equipped with a precise temperature probe that delivers restaurant-quality results every time. This professional-style baking stone comes standard with every electric wall oven.



Continú Clean™

Eco-friendly Continú Clean™ works every time the oven is on to help keep it cleaner without harsh chemicals or extreme temperatures. As needed, use the speedy Self Clean cycle.



Temperature Probe

Precision temperature probe offers the ideal way to obtain the perfect temperature for any meat. Simply insert the probe into your dish, set your desired temperature, and the oven will roast to the specified temperature.

BLUESTAR® 30" ELECTRIC WALL OVEN SERIES (24" & 36" COMING SOON)

Standard Features

- Powerful 2,500 watt bake element plus 1,500 watt heat assist for faster preheat
- Commercial-grade intense 5,000 watt infrared broiler for restaurant-quality results
- Built-in artisan baking stone with precise temperature control
- Touch screen control panel with 12 cooking modes, including StoneBake™, Convection & Sabbath
- Precision temperature probe delivers perfect temperature control
- Extra-large oven capacity – accommodates a full-size 18" x 26" baking sheet*
- Eco-friendly Continu Clean™ feature continuously cleans the oven cavity
- Available in 750+ colors and finishes, plus multiple door options
- Convection oven cooking
- Full extension oven rack
- High visibility dual halogen oven lights

BLUESTAR ELECTRIC WALL OVEN SWING DOOR 24", 30", 36"

DIM	24" OVEN	30" OVEN	36" OVEN
A	24	30	36
B	23-1/2	29-1/2	35-1/2

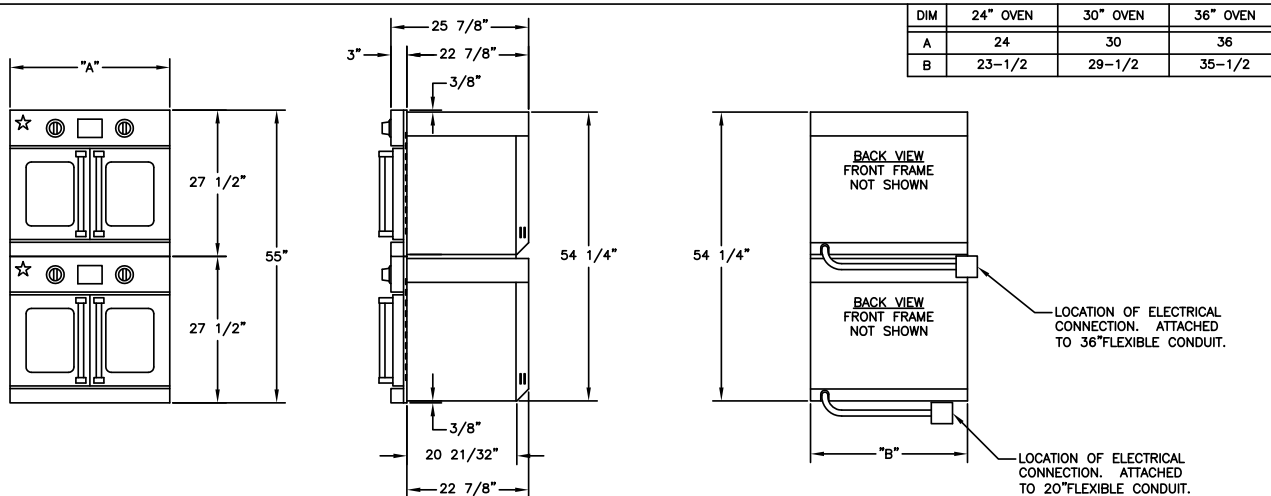
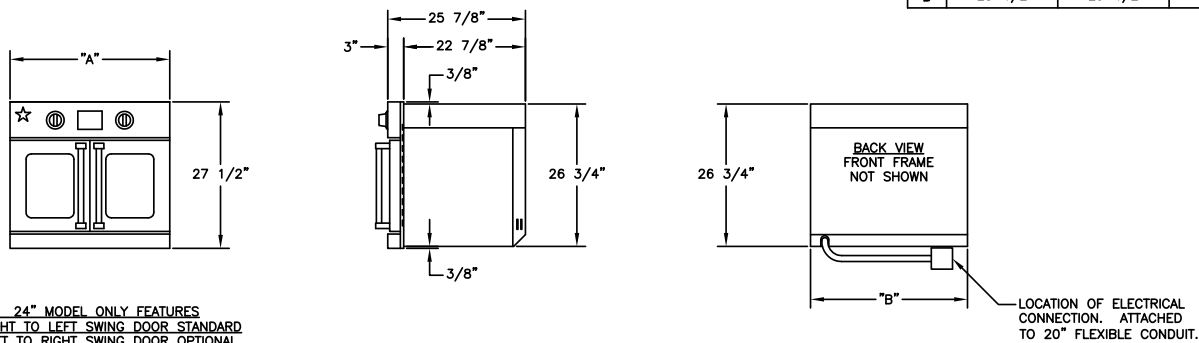

SPECIFICATIONS:

- OVEN INTERIOR:
 24" OVEN: ----- 20.25"W x 20"D x 15"H
 30" OVEN: ----- 26.25"W x 20"D x 15"H
 36" OVEN: ----- 29"W x 20"D x 15"H
- OVEN BAKE ELEMENT RATING ___ 2500 WATTS
- OVEN BROILER ELEMENT RATING __ 5000 WATTS
- OVEN HEAT ASSIST ELEMENT ___ 1500 WATTS
- ELECTRICAL REQUIREMENTS:
 EACH OVEN ----- 240V, 60Hz, 35 AMPS, 1 PH
 (UNIT MUST BE ON A NON-GFI, DEDICATED OUTLET)

1113-01-RevA