

## BLUESTAR 60" RNB SERIES

With over 130 years of experience making cooking equipment, and as the leading manufacturer of high-performance commercial-style ranges for the home, it is no surprise that BlueStar™ makes the finest residential ranges available. The unparalleled accuracy of gas surface cooking and the versatility found in the baking and roasting qualities of our convection oven make this an unsurpassed addition to every cook's favorite room in the house. Heavy-duty construction combined with innovative features produce an appliance of uncompromising durability, functionality, and beauty that will be the focal point of your kitchen for years to come!

### BlueStar 60" RNB Series

- ULTRANOVA™ power burner delivers 22,000 BTUs of intense heat.
- Both ovens accommodate a full-size commercial size 18" x 26" baking sheet.
- 24" depth for compatibility with standard kitchen cabinetry.
- Available in 190 colors.



▲ *Model RNB608GSS in Stainless Steel with standard 6" Low Profile backguard.*



### NOVA™, ULTRANOVA™ and Simmer Burners

Our cast iron porcelain-enameled NOVA™ and ULTRANOVA™ top burners are the most versatile burners in the industry. The Nova burner provides up to 15,000 BTUs of cooking power. For that extra boost, the ULTRANOVA™ delivers an amazing 22,000 BTUs; a rapid boil or superior sauté is never a problem! When using our gentle 130°F simmer feature, delicate sauces and soups are made simple with superior temperature control and flame disbursement.

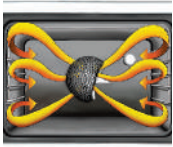

### Convection Oven Cooking

The cavity design of the oven and the convection fan system result in the most complete exchange of air possible. This provides incredibly precise, even heat distribution. Both ovens provide extra large oven capacity on a 60" range and will accommodate a commercial-size 18" x 26" baking sheet.



### Infrared Broiler

Because of its popularity in the commercial market, the direct-fired ceramic infrared broiler is standard on all residential ranges. The large burner produces 1850°F of intense, searing heat close to the burner, while effecting a gentler broiling for foods placed farther away. The broiler is fully recessed into the oven's top to create maximum cooking space.



### Full Motion Grates

Bring sauce to a boil while stirring on a front burner, then slide it to the rear to simmer while you sauté up front! Our full motion grates allow you to easily reposition pots and pans from front to rear burners without lifting. The grates are also oversized to accommodate the largest stock pots and sauté pans.

# BLUESTAR 60" RNB SERIES

## Standard Features

- Heavy-duty, commercial stainless steel construction.
- Automatic electronic ignition and re-ignition system.
- Convection system.
- Interior oven light.
- Ceramic infra-red broiler.
- Commercial quality oven control.
- Heavy-duty oven door.
- Push-to-turn, infinite setting NOVA™ and ULTRANOVA™ top burner controls with new 130°F simmer burner.
- Heavy-duty steel alloy control knobs.
- Removable dishwasher friendly stainless steel drip trays.
- 2 Extra large ovens. Oven capacity 26.25"W x 20"D x 15"H each.
- 1 year parts and labor warranty.

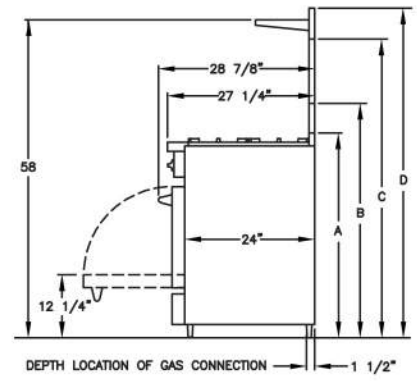
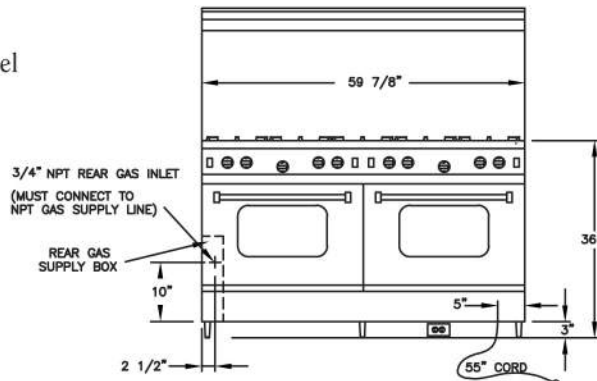

ELECTRICAL CORD LOCATED IN BACK OF UNIT  
LOCATION OF ELECTRICAL OUTLET MUST NOT BE HIGHER THAN 3" FROM FLOOR IF LOCATED BEHIND THE UNIT OR CAN BE LOCATED IN AN ADJOINING CABINET.

A - ISLAND TRIM HEIGHT - 38 1/4"  
B - 6" STANDARD BACKGUARD HEIGHT - 43 1/4"  
C - 17" BACKGUARD HEIGHT - 54 1/4"  
D - HIGH SHELF BACKGUARD HEIGHT - 61"

Top Burner Rating .....	15,000 BTU	Simmer Burner Rating .....	130°F
Top Power Burner Rating .....	22,000 BTU	Electrical Requirements .....	120 VAC, 15 Amps (Unit must be on a non-GFI dedicated outlet) Single Phase
Infrared Broiler Rating .....	15,000 BTU	Operating Gas Pressure .....	NAT: 5.0" WC LP: 10.0" WC
Charbroiler Burner Rating .....	15,000 BTU	Installation Clearance .....	0" Side Cabinet 0" Back Wall
Griddle Burner Rating .....	15,000 BTU		
Oven Burner Rating .....	30,000 BTU		

\*\* All specifications are subject to change without prior notification.

## BlueStar Backguard Options



### Island Trim Back

Allows flush-mounting into an island. Oven vents through top of back.

(Shown on 36" Model)



### 6" Low Profile Back

Protects the back wall while allowing for custom treatment.

(Shown on 24" Model)



### 17" Backguard

Provides commercial aesthetics and professional style.

(Shown on 48" Model)



### 24" High Shelf

Produces a true gourmet professional look while providing a convenient holding area for plates and prepared food.

(Shown on 36" Model)

## BlueStar 60" RNB Configuration

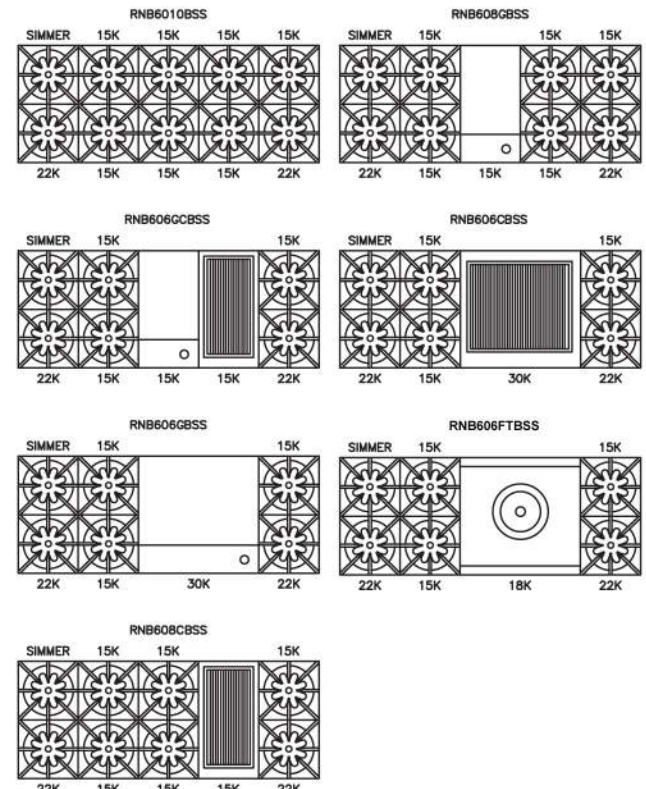

## Accessories

- Castors
- Wok Ring

## Additional Products

- Cooktops
- Rangetops
- Wall Ovens
- Barbecue Grills
- Hoods
- Warming Drawers
- Indoor Charbroilers
- Salamander Broiler

