

The newly redesigned Heritage Classic Series features restaurant quality performance and nearly unlimited customization options. These units also include a professional raised griddle/broiler for melting cheeses and edge-browning the finishing touch on special dishes.



## PRODUCT FEATURES

- UltraNova™ power burner delivers 22,000 BTUs of intense heat
- Gentle 130° simmer burner
- Includes 24" raised griddle/broiler for melting and edge-browning
- Available backguard options: 17" or 24"
- Available in 750+ colors and finishes

## SPECIFICATIONS

Rangetop Dimensions: 59.875"W x 24"D x 36.75"H

Top Burner Rating: 22,000 BTUs

Simmer Burner Rating: 9,000 BTUs

Raised Griddle Burner Rating: 30,000 BTUs

Electrical Requirements: 120V, 60Hz, 15 AMPs, 1 PH  
(Unit must be on a Non-GFI, dedicated outlet)

Operating Gas Pressure: NAT: 5.0" WC, LP: 10.0" WC

Gas Line Size: 3/4"

Installation Clearance: 0" Side Cabinet, 0" Back Wall

## MODEL CONFIGURATION

Six Burners

RGTNB606GHCV2

with 24" Griddle

## BURNER CONFIGURATION

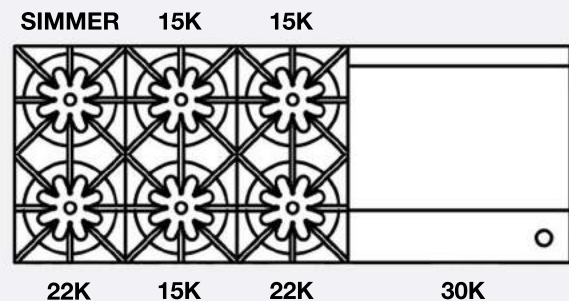

## ADDITIONAL CUSTOMIZATION OPTIONS

- Burner configurations
- Backguard options
- Knob colors
- Trim options

*All specifications subject to change without notice.  
Visit [www.bluestarcooking.com](http://www.bluestarcooking.com) prior to site preparation or installation.*

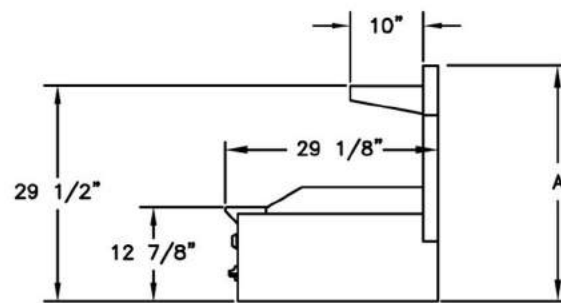
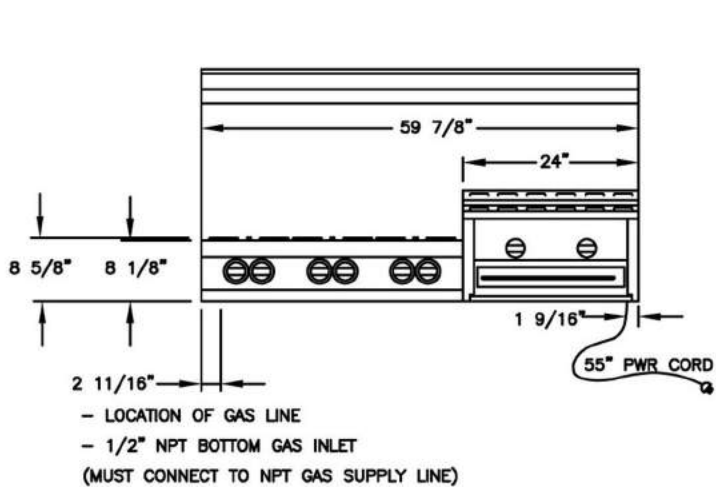

LOCATION OF ELECTRICAL CONNECTION  
 NOTE: A HOLE MUST BE DRILLED INTO THE BASE CABINET TO ACCEPT ELECTRICAL CORD.

LOCATION OF GAS LINE  
 NOTE: A HOLE MUST BE DRILLED INTO THE BASE CABINET TO ACCEPT GAS LINE.

- A [ 17" BACKGUARD HEIGHT -  $25-9/16"$
- 24" HIGH SHELF BACKGUARD HEIGHT -  $32\ 5/16"$
- 24" HIGH BACKGUARD HEIGHT -  $32\ 5/16"$

## RELATED PRODUCTS

### VENTILATION

