



# Platinum Gas Rangetop User Manual



## Thank You and Welcome

Thank you for your purchase and welcome to the BlueStar family!

BlueStar appliances are designed for discerning home chefs who demand restaurant-quality results in their own kitchens. As the owner of a new BlueStar appliance, you can look forward to years of precise and even cooking in your home kitchen.

Here are a few tips to get started:

1. Review this User Manual, which includes instructions and tips for getting the most out of your new appliance.
2. Register your appliance online at [www.bluestarcooking.com/support/product-registration](http://www.bluestarcooking.com/support/product-registration) to stay in touch and allow us to send you valuable product news and updates.
3. Review our products and help us spread the word at <https://www.bluestarcooking.com/inspiration/reviews>.

Thank you again for choosing BlueStar.

## Contents

Safety Information .....	5
Site Preparation .....	10
Installation Instructions .....	19
Before Your First Use .....	24
Operation .....	31
Cooking Guide and Tips.....	34
Common Baking Problems and Solutions .....	42
Care and Cleaning .....	43
Troubleshooting .....	45
Warranty .....	47

## Product Information

Important product information, including the model and serial numbers, can be found on the serial plate, which is located on the bottom of the rangetop behind the stainless steel control panel.

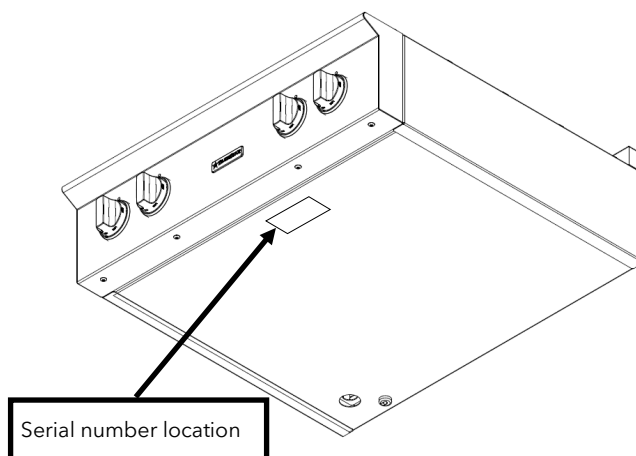

Please complete the information below for warranty purposes and future reference:

Model Number \_\_\_\_\_

Serial Number \_\_\_\_\_

Installation Date \_\_\_\_\_

Dealer's Name \_\_\_\_\_

Dealer's Phone Number \_\_\_\_\_

If service is required under warranty, it must be performed by an authorized BlueStar service company. To locate an authorized BlueStar service company in your area, go to [www.bluestarcooking.com/support/find-a-service-center](http://www.bluestarcooking.com/support/find-a-service-center).

## Safety Information

Please read and comply with the following safety messages to ensure your cooking product is installed and operated as safely as possible.

**DANGER** states a hazard that will cause serious injury or death if precautions are not followed.

**WARNING** states a hazard that can cause serious injury or death if precautions are not followed.

**CAUTION** states a hazard that can cause minor injury or product damage if instructions are not followed.

**NOTICE** highlights important information that is not related to physical injury.

This appliance is designed for easy installation and operation, however we recommend that you read all sections of this manual before installation and first use.

### **WARNING**

**WARNING:** If the information in these instructions is not followed exactly, a fire or explosion may result causing property damage, personal injury or death.

- Do not store or use gasoline or other flammable vapors and liquids in the vicinity of this or any other appliance.
- **WHAT TO DO IF YOU SMELL GAS**
  - Do not try to light any appliance.
  - Do not touch any electrical switch.
  - Do not use any phone in your building.
  - Immediately call your gas supplier from a neighbor's phone. Follow the gas supplier's instructions.
  - If you cannot reach your gas supplier, call the fire department.
- Installation and service must be performed by a qualified installer, service agency or the gas supplier.

### **WARNING**

**Never Operate the Top Surface Cooking Section of this Appliance Unattended**

- Failure to follow this warning statement could result in fire, explosion, or burn hazard that could cause property damage, personal injury, or death.
  - If a fire should occur, keep away from the appliance and immediately call your fire department.
- DO NOT ATTEMPT TO EXTINGUISH AN OIL/GREASE FIRE WITH WATER.**

### **WARNING**

**NEVER** cover any slots, holes or passages in the oven bottom or cover an entire rack with materials such as aluminum foil. Doing so blocks airflow through the oven and may cause carbon monoxide poisoning. Aluminum foil linings may also trap heat, causing a fire hazard.

## Safety Information (continued)

### Electrical Requirements and Grounding Instructions

Installation and service must be performed by a qualified installer, service agency, or utility company. The appliance must be electrically grounded in accordance with local codes or, in the absence of local codes, with the National Electrical Code, NFPA 70, or the Canadian Electric Code, CSA C22.1-02.

### WARNING

Installation must conform with local codes or, in the absence of local codes, to the National Fuel Gas Code, ANSI Z223.1/NFPA 54, or, in Canada, the National Gas and Propane Installation Code, CSA 8149.1.

The installation of appliances designed for manufactured (mobile) home installation must conform to the Manufactured Home Construction and Safety Standard, Title 24 CFR, Part 3280 (formerly the Federal Standard for Mobile Home Construction and Safety, Title 24 HUD (Part 280), or with local codes where applicable.

The installation of appliances designed for Recreation Park Trailers must conform with state and local codes, or, in the absence of such codes, to the standard for Recreational Park Trailers ANSI A119.5.

### WARNING

- A manual gas shutoff valve is to be installed in an accessible location in the gas line, external to the appliance to allow gas to be turned on and off to the appliance.
- Any openings in the wall directly behind the appliance and in the floor below the appliance must be sealed prior to installation and use of the appliance.
- Units with a char-broil burner must have non-combustible material used in the construction of the underside of the cabinet above the unit or a ventilation hood must be installed above the unit or in accordance with local codes, or in the absence of local codes, with the National Fuel Gas Code, ANSI Z223.1/NFPA 54 or, in Canada, the Natural Gas and Propane Installation Codes CSA B149.1.
- Leak testing of the appliance must be conducted according to the manufacturer's instructions.
- In the event of a power failure, do not attempt to operate the appliance or light any of the burners. This is a gas fired appliance that uses electrical components as ignition and safety devices.
- Before any maintenance or repair, disconnect the appliance from the electric supply.

### WARNING

To reduce the risk of fire, electric shock, serious injury, or death when using your appliance, follow basic safety precautions, including the following:

- Read the provided user manual before operating this appliance.
- This product is to be used only for cooking tasks expected of a home appliance. This product is not intended for commercial use.
- If your product is found to be damaged upon receipt, contact your dealer or builder immediately. Do not install or use a damaged appliance or if the conduit is damaged.
- Do not install, repair, or replace any part of the appliance yourself unless specifically recommended in the literature accompanying it. All other service must be performed by a qualified service technician.
- Electric power to the appliance must be turned off at the circuit breaker or fuse box prior to performing any type of service or installation.
- This appliance must be properly installed and grounded by a qualified installer according to these installation instructions prior to use. The installer must show the customer the location of the circuit breaker panel or fuse box so that they know where and how to turn off electric power to the appliance. BlueStar is not responsible for service required to correct a faulty installation. The owner is responsible to make sure this appliance is properly installed.
- To avoid electric shock hazard, do not install this appliance outside or near water. Do not install or use this appliance if it has been exposed to water.
- Do not obstruct any venting areas or slots. The appliance must be installed in a manner which will keep the area below the door unobstructed to allow free air flow.
- Do not tamper with the controls. Do not adjust or alter any part of the appliance unless specifically instructed to do so by this manual.
- Secure the appliance to the cabinet following the direction in the installation instructions to prevent injury due to the unit tipping forward.
- This appliance must be installed by a qualified gas technician. Have the technician show you the exact location of the gas shutoff valve on the incoming gas line so you know how to turn off the gas if necessary.

## Safety Information (continued)

### **WARNING**

To reduce the risk of fire, electric shock, serious injury, or death when using your appliance, follow basic safety precautions, including the following:

- To prevent damage, do not use the knobs or bezels as lift points or for moving the appliance
- Do not climb or sit on any part of the appliance.
- Keep packaging materials away from children. Plastic sheets and bags can cause suffocation.
- Do not leave children or pets alone or unattended in the area around the appliance. Do not allow children to play with the controls, pull on the handle, or touch other parts of the appliance
- Do not store items of interest to children above the appliance. Children can be burned or injured while climbing on the appliance.
- Install a smoke detector near the kitchen.
- Do not use water on grease fires. Smother any flames with a lid, cookie sheet, or flat tray. Use baking soda or a foam fire extinguisher to extinguish flaming grease. If a fire occurs, keep the oven door closed.
- Keep flammable items, such as paper, cardboard, plastic, and cloth away from hot surfaces. Do not put such items in the oven. Do not allow potholders to touch hot surfaces.
- Only use dry potholders to prevent steam burns when moving items on or off of the appliance. Do not use a towel or other bulky cloth in place of potholders.
- Wear proper attire. Do not wear loose or hanging apparel while using the appliance. Do not allow clothing to come into contact with or within close proximity of any element or the interior of the oven and the surrounding areas during and immediately after use. Some synthetic materials are highly flammable and should not be worn while cooking.
- Do not store combustible, flammable, or explosive materials in adjacent cabinets.
- Never use the appliance for warming or heating the room.
- Use caution when adding liquids to food or containers. Steam can cause serious burns or scalding.
- Do not heat unopened food containers. Build up of pressure may cause the container to burst and result in injury.
- Grease is flammable. Let hot grease cool before attempting to handle it. Avoid letting grease accumulate anywhere on the appliance.
- Be sure all appliance controls are turned off and the appliance is cool before using any type of aerosol cleaner on or around the appliance. A chemical that produces the spraying action could, in the presence of heat, ignite or cause metal parts to corrode.
- Clean parts only as listed in the user manual.
- Do not install or use any ventilation system which uses a downward airflow with this appliance.

## Information sur la sécurité

Veillez lire et respecter les messages de sécurité suivants pour vous assurer que votre appareil de cuisson est installé et utilisé de la manière la plus sûre possible.:

**DANGER** indique un danger qui entraînera des blessures graves ou la mort si les précautions ne sont pas respectées.

**AVERTISSEMENT** indique un danger qui peut entraîner des blessures graves ou la mort si les précautions ne sont pas respectées.

**ATTENTION** signale un danger pouvant entraîner des blessures mineures ou endommager le produit si les instructions ne sont pas suivies.

**NOTE** met en évidence des informations importantes qui pas liées à des blessures physiques.

Cet appareil est conçu pour une installation et un fonctionnement faciles, cependant nous vous recommandons de lire toutes les sections de ce manuel avant l'installation et la première utilisation.

### Exigences électriques et instructions de mise à la terre

L'installation et l'entretien doivent être effectués par un installateur qualifié, une agence de service ou une entreprise de services publics.

**AVERTISSEMENT:** L'installation doit être conforme aux codes locaux ou, en l'absence de codes locaux, au National Fuel Gas Code, ANSI Z223.1/NFPA54 et au National Electrical Code NFPA70.

L'installation d'appareils conçus pour une installation dans une maison préfabriquée (mobile) doit être conforme à la norme de sécurité et de construction de maisons préfabriquées, titre 24 CFR, partie 3280, ou, lorsque cette norme ne s'applique pas, se référer à : ANSI/NCSBCS A225.1 ou avec codes locaux, le cas échéant.

L'installation d'appareils conçus pour les remorques de parc de loisirs doit être conforme aux codes nationaux et locaux ou, en l'absence de tels codes, à la norme pour les remorques de parc de loisirs ANSI A119.5.

## ⚠ AVERTISSEMENT

Pour réduire les risques d'incendie, d'électrocution, de blessures graves ou de mort lors de l'utilisation de votre appareil, suivez les précautions de sécurité de base, notamment les suivantes:

- Lisez le manuel d'utilisation fourni avant d'utiliser cet appareil.
- Ce produit doit être utilisé uniquement pour les tâches de cuisson attendues d'un appareil électroménager. Ce produit n'est pas destiné à un usage commercial.
- Si votre produit s'avère endommagé à la réception, contactez immédiatement votre revendeur ou le constructeur. Ne pas installer ou utiliser un appareil endommagé ou dont le conduit est endommagé.
- N'installez, ne réparez ou ne remplacez aucune pièce de l'appareil vous-même, sauf si cela est spécifiquement recommandé dans la documentation qui l'accompagne. Tout autre service doit être effectué par un technicien de service qualifié.
- L'alimentation électrique de l'appareil doit être coupée au niveau du disjoncteur ou de la boîte à fusibles avant d'effectuer tout type d'entretien ou d'installation.
- Cet appareil doit être correctement installé et mis à la terre par un installateur qualifié conformément à ces instructions d'installation avant utilisation. L'installateur doit montrer au client l'emplacement du panneau de disjoncteurs ou de la boîte à fusibles afin qu'il sache où et comment couper l'alimentation électrique de l'appareil. BlueStar n'est pas responsable du service requis pour corriger une installation défectueuse. Le propriétaire est responsable de s'assurer que cet appareil est correctement installé.
- Pour éviter tout risque d'électrocution, n'installez pas cet appareil à l'extérieur ou à proximité de l'eau. Ne pas installer ou utiliser cet appareil s'il a été exposé à l'eau.
- Ne pas obstruer les zones ou les fentes de ventilation. L'appareil doit être installé de manière à garder la zone sous la porte dégagée pour permettre la libre circulation de l'air.
- Ne modifiez pas les commandes. N'ajustez ou ne modifiez aucune pièce de l'appareil à moins d'y être spécifiquement invité par ce manuel.

## Informations de sécurité (suite)

### AVERTISSEMENT

Pour réduire les risques d'incendie, d'électrocution, de blessures graves ou de mort lors de l'utilisation de votre appareil, suivez les précautions de sécurité de base, notamment les suivantes:

- Fixez l'appareil à l'armoire en suivant les instructions des instructions d'installation pour éviter les blessures dues au basculement de l'appareil vers l'avant.
- Pour éviter tout dommage, n'utilisez pas les poignées du four comme points de levage ou pour déplacer l'appareil
- Ne grimpez pas et ne vous asseyez sur aucune partie de l'appareil.
- N'utilisez jamais la porte du four pour marcher, vous appuyer ou vous asseoir. Des dommages à l'appareil et/ou des blessures corporelles peuvent survenir.
- Gardez les matériaux d'emballage hors de portée des enfants. Les feuilles et les sacs en plastique peuvent provoquer une suffocation.
- Ne laissez pas les enfants ou les animaux domestiques seuls ou sans surveillance dans la zone autour de l'appareil. Ne laissez pas les enfants jouer avec les commandes, tirer sur la poignée ou toucher d'autres parties de l'appareil
- Attention : ne rangez pas d'objets intéressants pour les enfants au-dessus de l'appareil. Les enfants peuvent se brûler ou se blesser en grimpant sur l'appareil.
- Installez un détecteur de fumée près de la cuisine.
- Ne pas utiliser d'eau sur les feux de graisse. Éteignez les flammes avec un couvercle, une plaque à biscuits ou un plateau plat. Utilisez du bicarbonate de soude ou un extincteur à mousse pour éteindre la graisse enflammée. En cas d'incendie, gardez la porte du four fermée.
- Gardez les articles inflammables, tels que le papier, le carton, le plastique et les tissus, à l'écart des surfaces chaudes. Ne mettez pas de tels articles dans le four. Ne laissez pas les maniques toucher les surfaces chaudes.
- Utilisez uniquement des maniques sèches pour éviter les brûlures de vapeur lorsque vous déplacez des articles dans ou hors de l'appareil. N'utilisez pas de serviette ou d'autre chiffon volumineux à la place des maniques.
- Lorsque vous utilisez le four, ne touchez pas les éléments chauffants ou les surfaces intérieures du four ou la zone extérieure entourant immédiatement la porte. Les éléments chauffants peuvent être chauds même s'ils sont de couleur foncée. Les surfaces intérieures du four peuvent devenir suffisamment chaudes pour causer des brûlures.
- Portez une tenue correcte. Ne portez pas de vêtements amples ou suspendus lors de l'utilisation de l'appareil. Ne laissez pas les vêtements entrer en contact avec ou à proximité de tout élément ou de l'intérieur du four et des zones environnantes pendant et immédiatement après l'utilisation. Certains matériaux synthétiques sont hautement inflammables et ne doivent pas être portés pendant la cuisson.
- N'utilisez pas le four pour le stockage.
- Ne stockez pas de matériaux combustibles, inflammables ou explosifs dans le four ou dans des armoires adjacentes.
- N'utilisez jamais l'appareil pour réchauffer ou chauffer la pièce.
- Ne recouvrez pas le four de papier d'aluminium ou d'autres matériaux pendant la cuisson ou le nettoyage.
- Ne laissez pas d'objets métalliques, tels que du papier d'aluminium, la sonde à viande, des plaques à biscuits, etc. sur le fond du four. Les objets laissés au fond du four pourraient endommager le four et l'objet.
- Soyez prudent lorsque vous ouvrez la porte du four. Laissez l'air chaud ou la vapeur s'échapper avant de retirer ou de replacer les aliments dans le four.
- Soyez prudent lorsque vous ajoutez des liquides à des aliments ou des récipients dans un four chaud. La vapeur peut causer de graves brûlures ou échaudures.
- Ne chauffez pas les récipients alimentaires non ouverts. L'accumulation de pression peut faire éclater le récipient et entraîner des blessures.
- La graisse est inflammable. Laissez refroidir la graisse chaude avant d'essayer de la manipuler. Évitez de laisser les dépôts de graisse s'accumuler. Nettoyer après chaque utilisation.
- Les lentilles d'éclairage doivent toujours être en place lorsque le four est utilisé pour protéger les ampoules contre la casse.

## Informations de sécurité (suite)

---

### **AVERTISSEMENT**

Pour réduire les risques d'incendie, d'électrocution, de blessures graves ou de mort lors de l'utilisation de votre appareil, suivez les précautions de sécurité de base, notamment les suivantes:

- Les grilles du four doivent être positionnées lorsque le four est froid pour éviter les brûlures. Si une grille doit être déplacée alors que le four est chaud, ne laissez pas la manique entrer en contact avec les éléments chauffants chauds du four.
- Assurez-vous que toutes les commandes de l'appareil sont éteintes et que l'appareil est froid avant d'utiliser tout type de nettoyant en aérosol sur ou autour de l'appareil. Le produit chimique qui produit l'action de pulvérisation pourrait, en présence de chaleur, s'enflammer ou provoquer la corrosion des pièces métalliques.
- Nettoyez les pièces uniquement comme indiqué dans le manuel d'utilisation.
- Ne nettoyez pas les joints de la porte du four. Les joints de porte sont indispensables pour une bonne étanchéité du four. Des précautions doivent être prises lors du nettoyage pour éviter de frotter, d'endommager ou de déplacer le joint de sa position d'installation.

# Site Preparation – Electrical Requirements and Clearances

---

## Electrical Requirements

This appliance requires a grounded dedicated circuit with the following requirements:

- BSPGRT30 – 120 VAC, 60Hz, 1 amp
- BSPGRT36 – 120 VAC, 60Hz, 1 amp
- BSPGRT48 – 120 VAC, 60Hz, 1 amp
- BSPGRT60 – 120 VAC, 60Hz, 1 amp

The installation of this appliance must conform with all applicable local codes. The installed appliance must be electrically grounded in accordance with local codes or, In the absence of such codes, with the National Electrical Code, NFPA 70, or Canadian Electric Code, CSA C22-1.02.

## Clearances

When the appliance is installed in an island, the island trim itself should be kept at least 6" (152.4 mm) in a vertical plane below the top horizontal plane of the appliance and 6" (152.4 mm) above the top horizontal plane of the appliance from combustible materials at the rear.

When the appliance is installed in a zero clearance condition or is installed with any other backguard in a zero clearance condition. Use non-combustible/heat resistant materials in a vertical plane for at least 6" (152.4 mm) below the top horizontal plane of the appliance and 6" (152.4 mm) above the top horizontal plane of the appliance where the appliance meets the back wall.

The non-combustible material need not extend horizontally past the initial barrier thickness. The initial barrier should consist of materials such as ceramic tile, cement backer board, .032" (0.8 mm) thick stainless steel (with an air gap of 1/4" min.), or other non-combustible material. Non-combustible materials are defined as in the form in which the material is used and under the conditions anticipated, the material will not aid combustion or add appreciable heat to an ambient fire or materials that are in compliance with ASTM E 136.

Refer to the local building code for additional information.

## Unpacking

1. Check the package for damage. If any damage is visible the Bill of Lading it must be noted that Concealed Damage may be present, prior to signing. If visible damage is present, contact the Dealer from which the appliance was purchased.
2. Ensure the package is upright. If the package is not upright there is a possibility of major damage to the appliance. If damage is discovered, do not refuse delivery. Contact the dealer and file appropriate freight claims. Save all packaging materials. Do not contact the manufacturer. Your appliance was shipped from the dealer from which it was purchased. Shipping damage claims are to be resolved between the customer, the shipping carrier, and the dealer. The manufacturer may assist in resolving any such claims but such assistance does not relieve you of your responsibility.
3. Move the container as close to its installation location as possible. This will reduce moving and handling of the appliance once it is out of the shipping packaging.
4. Cut the straps and remove fasteners holding the carton to the pallet. Carefully lift the box directly up and off the appliance. Do not use a hammer. Do not cut the carton with a razor, utility knife, box cutting knife or other blade.
5. Thoroughly inspect the appliance for damage. If damage is discovered do not refuse delivery. Contact the dealer and file appropriate freight claims.
6. Remove and unpack any accessories shipped with your appliance. Make sure no hardware, accessories, or parts remain in the packaging and are unintentionally discarded.

# Site Preparation – Product Dimensions (BSPGRT30)

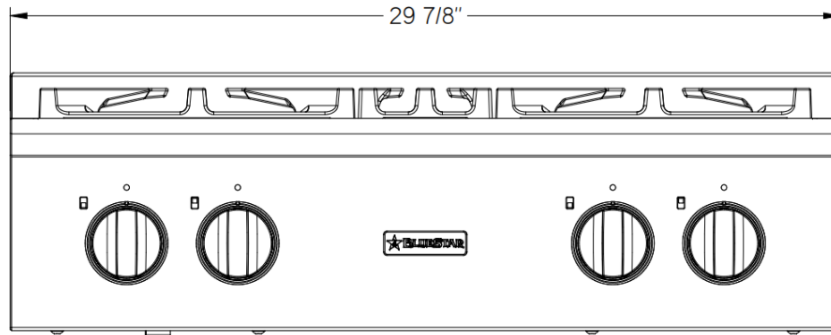

**FRONT VIEW**

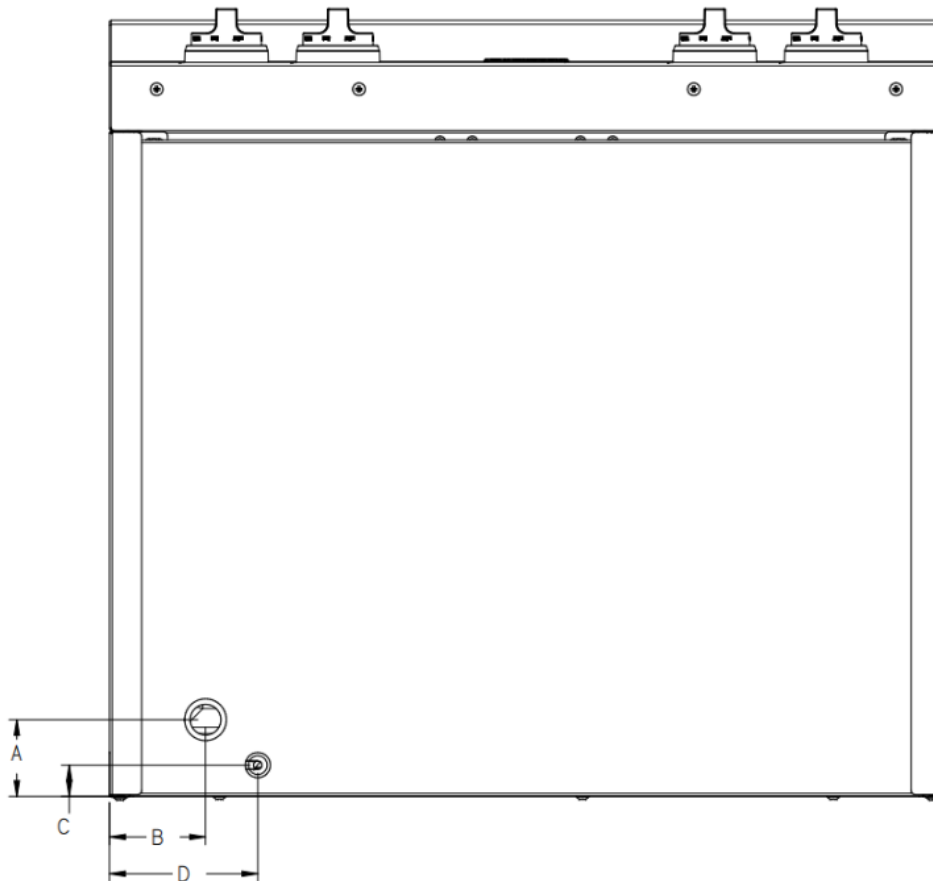

**BOTTOM VIEW**

	<b>GAS INLET LOCATION</b>		<b>ELECTRIC CORD LOCATION</b>
<b>A</b>	2-3/4" (69.9 mm)	<b>B</b>	3-7/16" (87.4 mm)
<b>C</b>	1-1/8" (28.5 mm)	<b>D</b>	5-5/16" (134.9 mm)

# Site Preparation – Product Dimensions (BSPGRT36)

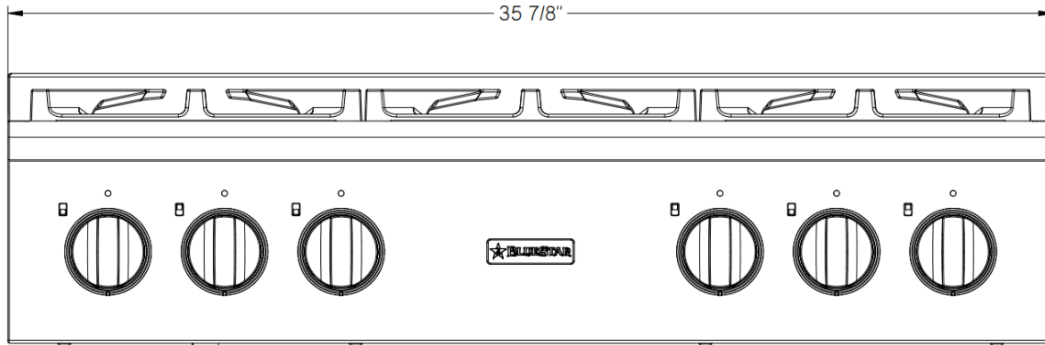

**FRONT VIEW**

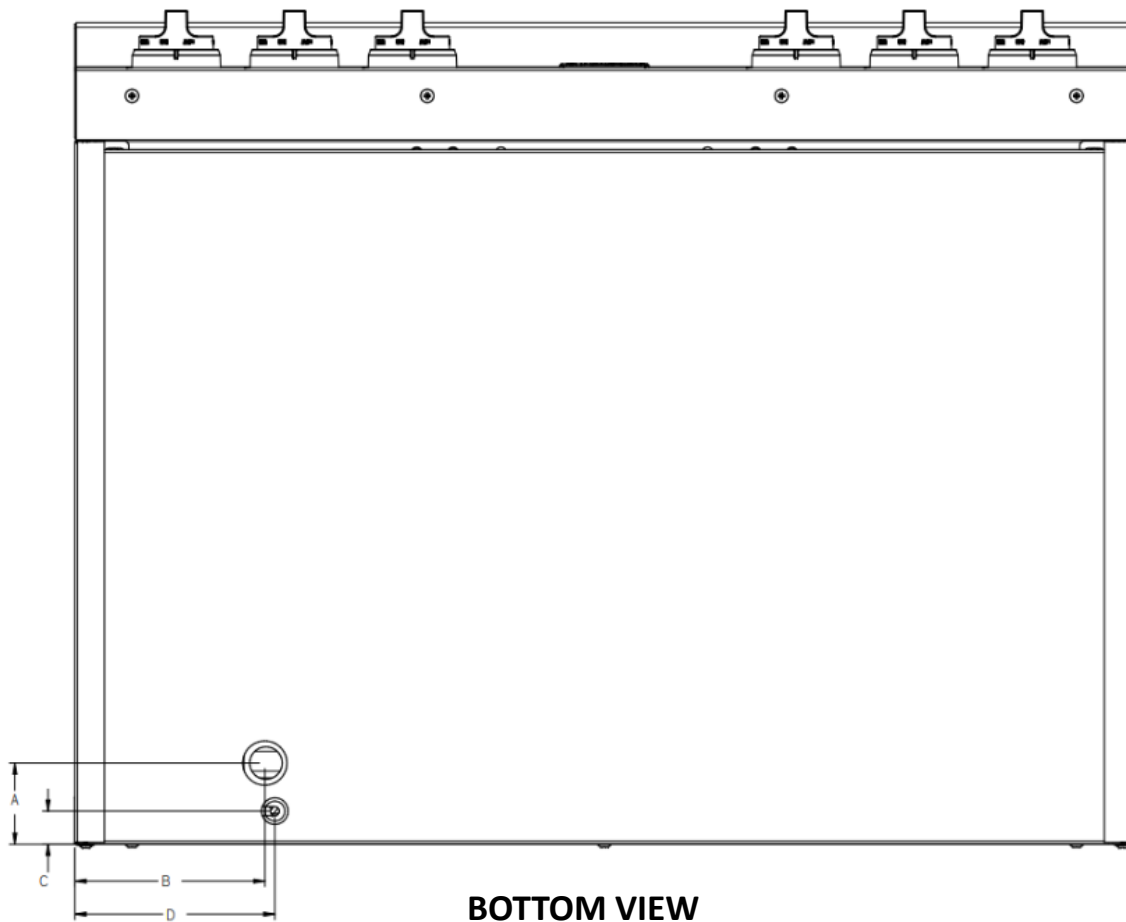

**BOTTOM VIEW**

	<b>GAS INLET LOCATION</b>		<b>ELECTRIC CORD LOCATION</b>
<b>A</b>	2-3/4" (69.9 mm)	<b>B</b>	6-7/16" (163.5 mm)
<b>C</b>	1-1/8" (28.5 mm)	<b>D</b>	6-3/4" (172.1 mm)

# Site Preparation – Product Dimensions (BSPGRT48)

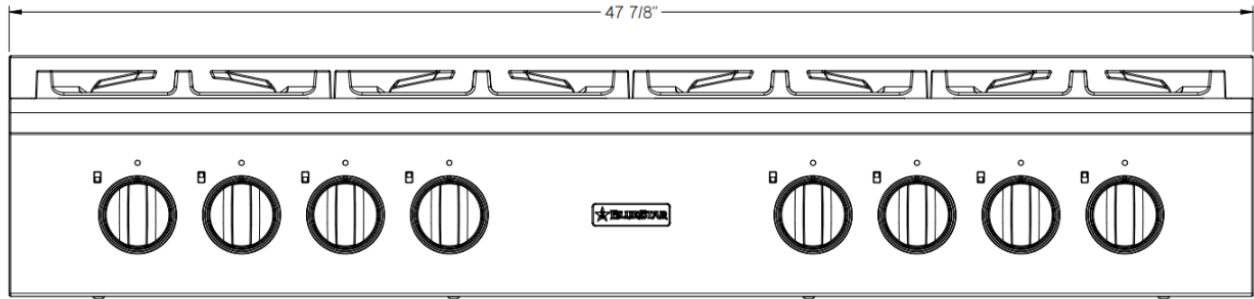

**FRONT VIEW**

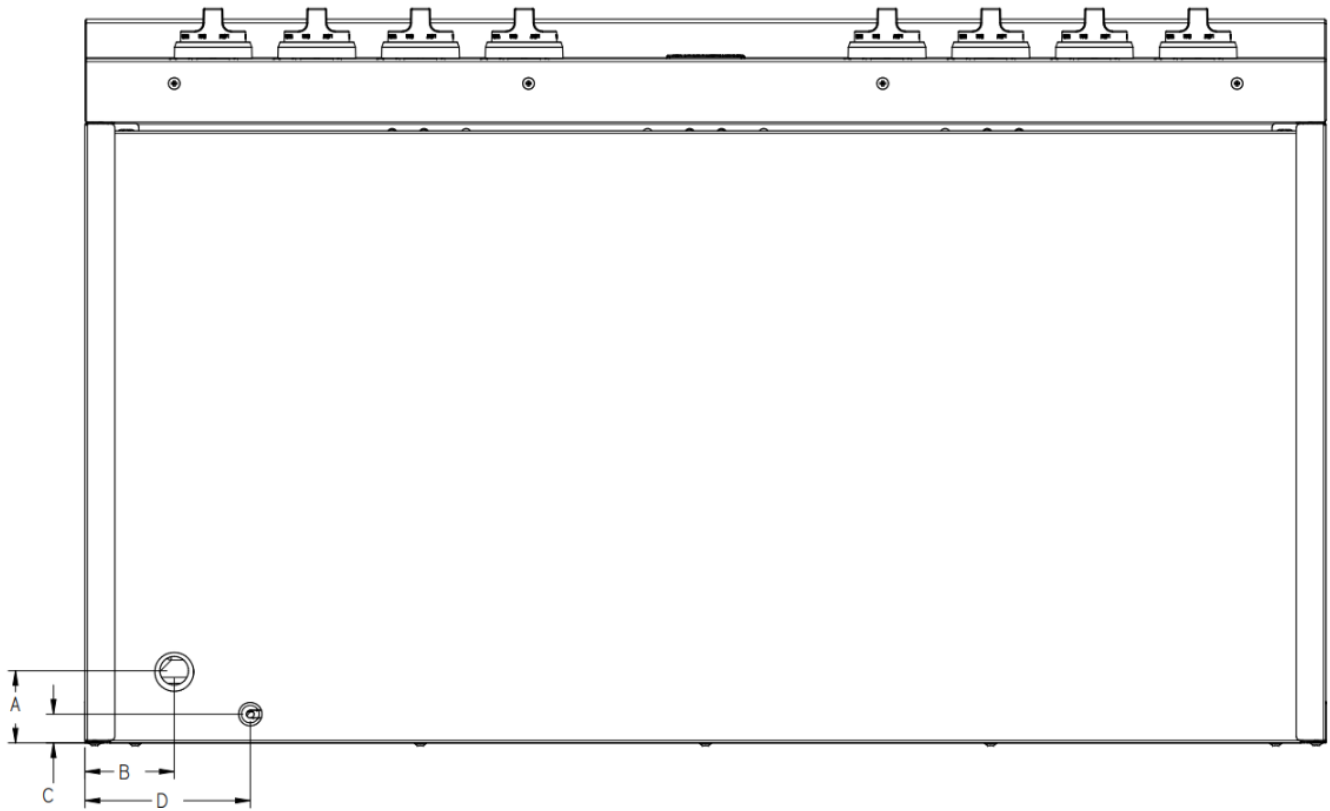

**BOTTOM VIEW**

	<b>GAS INLET LOCATION</b>		<b>ELECTRIC CORD LOCATION</b>
<b>A</b>	2-3/4" (69.9 mm)	<b>B</b>	3-7/16" (87.4 mm)
<b>C</b>	1-1/8" (28.5 mm)	<b>D</b>	6-3/8" (161.9 mm)

# Site Preparation – Product Dimensions (BSPGRT60)

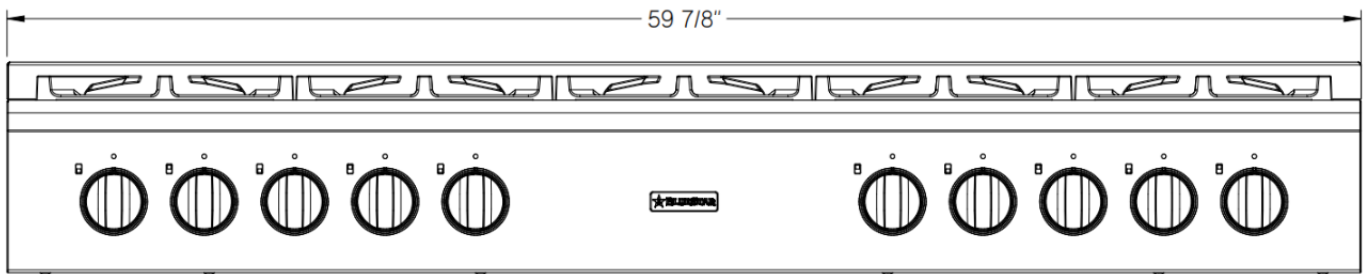

**FRONT VIEW**

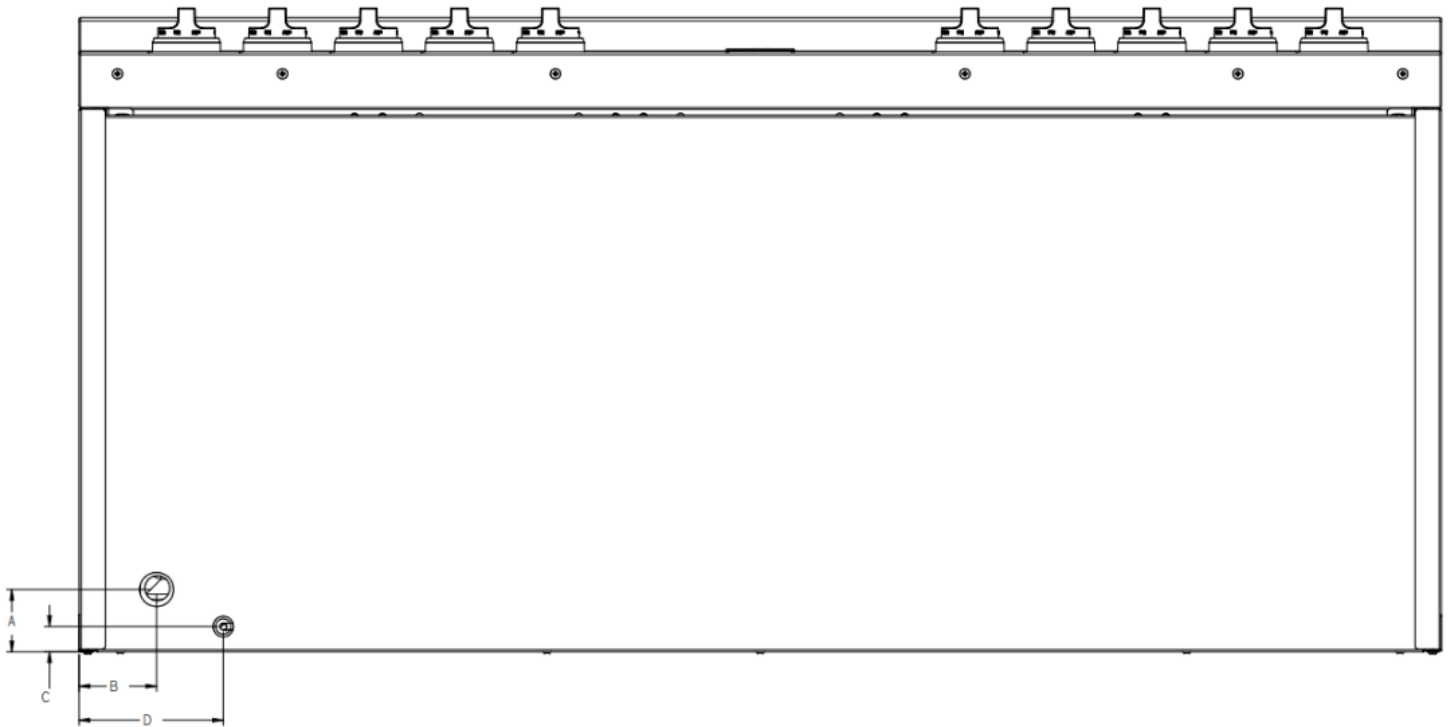

**BOTTOM VIEW**

	<b>GAS INLET LOCATION</b>		<b>ELECTRIC CORD LOCATION</b>
<b>A</b>	2-3/4" (69.9 mm)	<b>B</b>	3-3/8" (86.5 mm)
<b>C</b>	1-1/8" (28.5 mm)	<b>D</b>	6-5/16" (160.9 mm)

# Site Preparation – Product Dimensions Side View

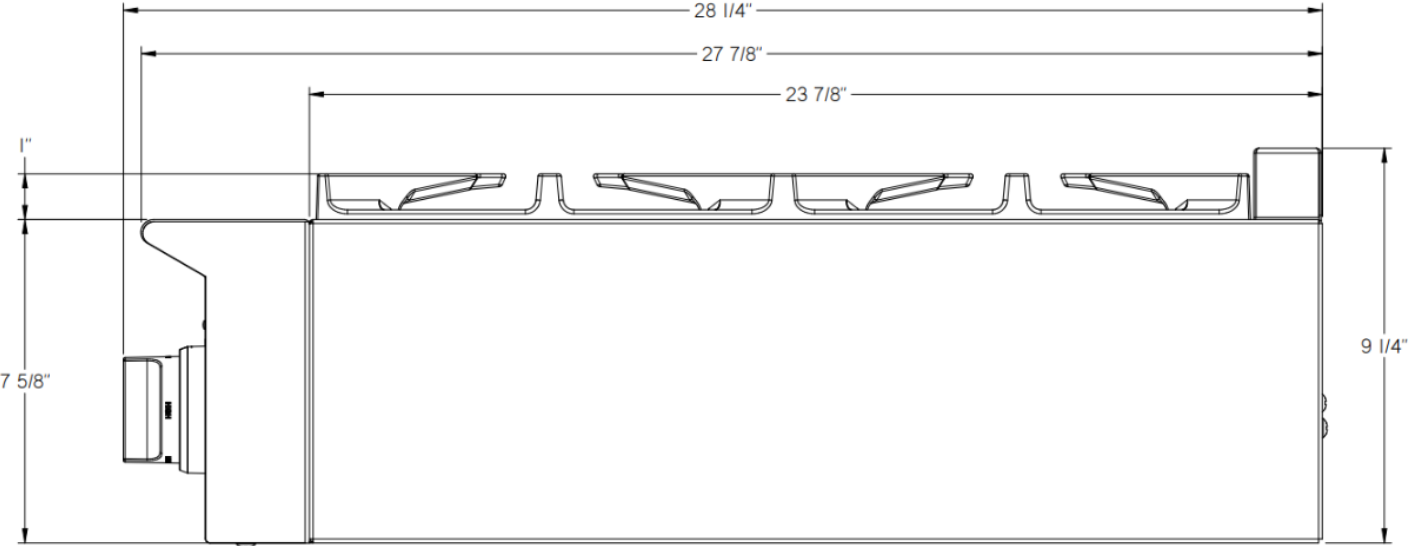

**SIDE VIEW (ALL SIZES)**

# Site Preparation – Cabinet Dimensions, Preparation, & Utility Location

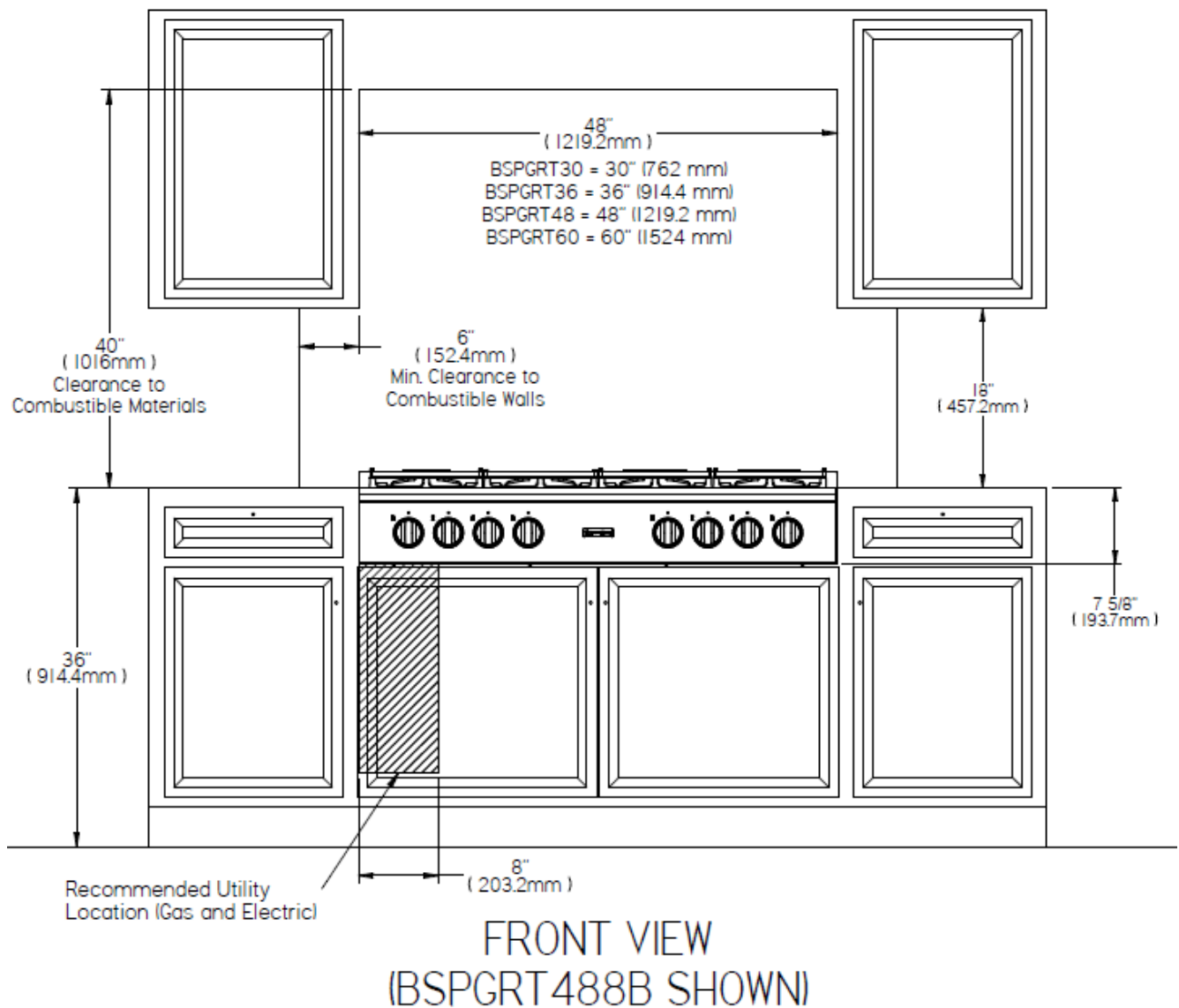
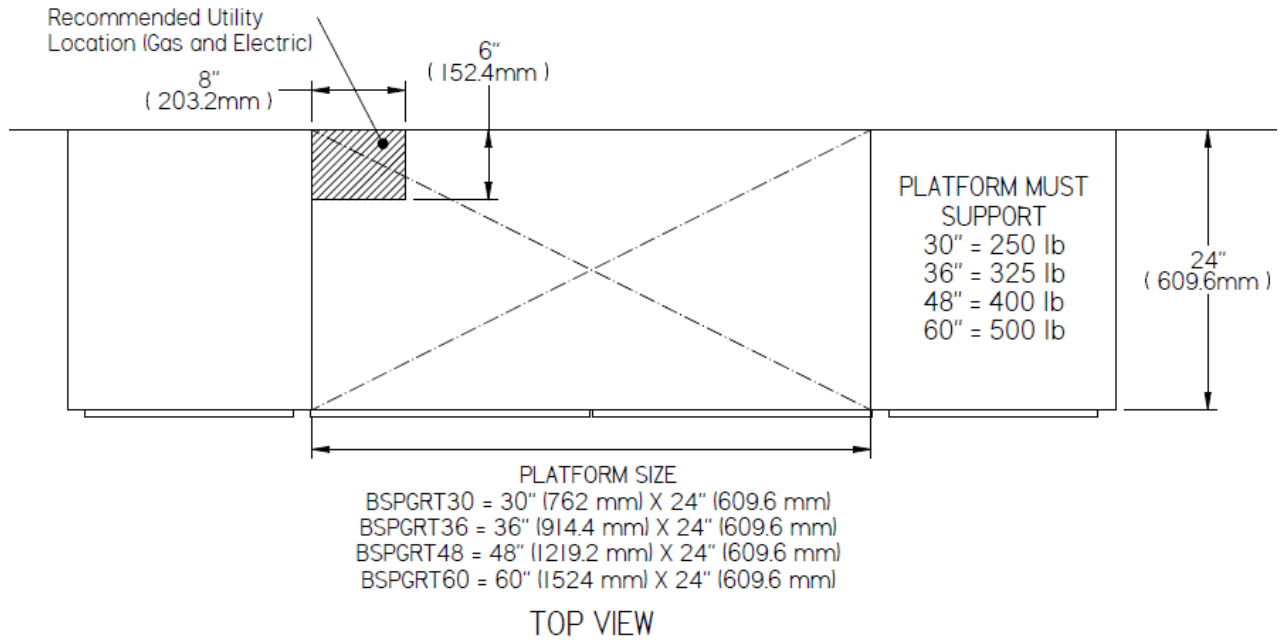

Cabinet Side View All Sizes

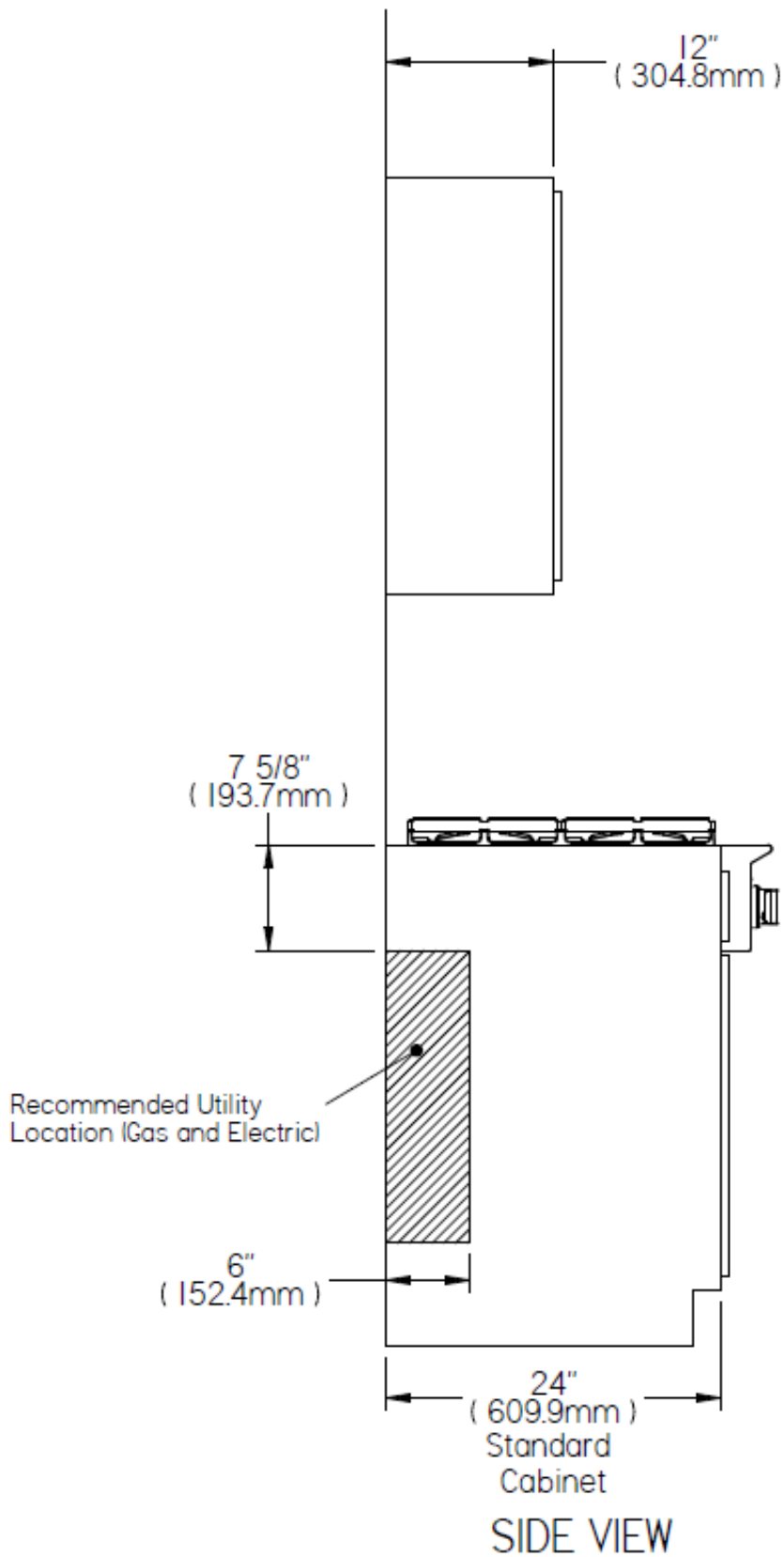

# Installation Instructions

## Tools and Materials

- Philips Screw Driver
- Level

### **⚠ WARNING**

This appliance is heavy and tips easily when not completely installed. Use two or more people to move and install the rangetop. Failure to follow these instructions can result in death or serious injury.

### **⚠ AVERTISSEMENT**

Cet appareil est lourd et bascule facilement lorsqu'il n'est pas complètement installé. Utilisez deux personnes ou plus pour déplacer et installer la cuisinière. Le non-respect de ces instructions peut entraîner la mort ou des blessures graves.

- Gloves and safety glasses

## Step 1 – Uncrate and Inspect the Rangetop

Uncrate and inspect the rangetop. Remove the packing materials but do not discard the user manual, grates, any accessories packed with the units, etc.

## Step 2 – Plan the Installation

The electric power cord and gas inlet are located on the left rear corner of the appliance on the bottom surface. Take caution when sliding the appliance onto the platform to prevent damage to the electrical cord and internal gas plumbing. Verify that the area below the platform allows sufficient clearance for the electrical cord and gas line as well as for the installation of the required gas regulator and a gas shutoff valve.

## Step 3 – Move the Rangetop into Position

Remove the hold down brackets securing the product to the pallet using a Philips screwdriver and discard the shipping screws and brackets. Use an appliance cart to move the rangetop near the front of the enclosure. Carefully lift the appliance using sufficient manpower or proper tools. Cautiously slide the rangetop into position. Verify the power cord is not pinched or compromised during the move.

Level the product (front to back / left to right).

## Step 4 – Connect Gas Supply

- The installation of this appliance must conform with all applicable local codes. In the absence of local codes, the installation must conform to the latest level of the National Fuel Gas Code, ANSI Z223.1/ NFPA 54.
- In Canada, the installation must be in accordance with the current CAN/CGA B149.1 and B149.2.
- You must have an individual manual shut-off valve installed in the gas supply line ahead of the appliance. This must be easily accessible in case of emergency.
- The included gas regulator must be installed into the gas pipe system.
- When pressure testing the piping systems the appliance and its individual shut-off valve must be disconnected from the gas supply piping during any pressure testing in excess of 1/2 psi (3.5 kPa).
- For tests equal to or less than 1/2 psi (3.5 kPa) the appliance must be isolated from the gas supply piping system by closing its manual shut-off valve.
- Incoming line pressure upstream of the appliance should be 1.0" WC greater than the operating manifold pressure. Service pressure may fluctuate for a variety of reasons. Under no circumstances should the factory-installed regulator be removed or bypassed.
- Maximum gas pressure must not exceed 14" water column (WC) or 1/2 psi.
- You can use either natural gas or liquid propane with this appliance. Verify whether the appliance and the incoming gas supply are compatible. Check the serial plate.
- The gas supply line must be the same size or larger than the gas inlet on the appliance. The appliance has either a 1/2" NPT or 3/4" NPT gas inlet connection. Make sure the supply line is 1/4" NPT larger than the appliance gas inlet.

## Installation Instructions (continued)

- The sealant used on the pipe joints must be resistant to LP gas.
- All gas cooking equipment must have a pressure regulator on the incoming service line for safe and efficient operation. This appliance is equipped with such a gas pressure regulator. Check the incoming gas pressure using a manometer. The correct manifold pressure for natural gas is 5.0" WC and for LP is 10" WC.
- The factory provided pressure regulator will withstand a maximum input pressure of 1/2 PSI (14" WC). If the incoming pressure exceeds the maximum rating, a step-down regulator is required.
- The appliance and its individual shut-off valve must be disconnected from the gas supply line during any pressure testing in excess of 1/2 PSI (3.5 kPa).
- Check to see that all installer-supplied pipes and fittings are clear of direct, threading chips or other foreign particles before connecting the appliance to the supply line. Such particles will clog orifices and/or valves when pressure is applied.
- The incoming gas supply is brought from the inlet pipe. This is the only connection required via the installer-supplied shut-off valve.
- If installing the appliance with flexible couplings and/or a "quick disconnect," use a commercially-approved AGA Design certified flexible connector at least 1/2" NPT that complies with ANSI Z21.41. In Canada, the connector must comply with CAN 16.10-88 and the "quick disconnect" device must comply with CAN 16.19M-79 and installed with a strain relief device.
- Before putting the appliance into service, test all gas connections for leaks. When pressure testing systems, do not exceed 1/2 PSI or damage will occur to the regulator. Use a soapy solution. Do not use an open flame to check for leaks. Such a procedure is dangerous and it may not detect all the small leaks that a soapy solution will.

### Step 5 – Connect Electrical Supply

Observe all local and other codes regarding electrical connections.

#### **WARNING**

This appliance must be grounded. Do not cut, remove, or disregard the grounding wire in this appliance. If the appliance is not grounded, severe shock hazards can exist and performance of the product can be negatively affected.

#### **AVERTISSEMENT**

Cet appareil doit être mis à la terre. Ne coupez pas, ne retirez pas et ne négligez pas le fil de mise à la terre de cet appareil. Si l'appareil n'est pas mis à la terre, de graves risques d'électrocution peuvent exister.

Installation and service must be performed by a qualified installer, service agency, or utility company.

Installation must comply with all applicable electrical codes.

1. The appliance is equipped with a standard three-prong polarized, NEMA 5-15P line cord to be plugged into a 120 volt, 15 amp outlet. The outlet must be connected to a dedicated breaker rated for 15 amps with a good connection to ground.
2. Removal of the grounding prong from the plug will void the manufacturer's warranty and can cause injury or death.
3. A dedicated ground is recommended for optimal performance. A poor ground will cause problems with burner ignition and operation.
4. The power cord is located at the left rear of the appliance (viewed from the front).
5. Turn power off at the breaker when connecting the power cord to the outlet.
6. Turn power on at the breaker after connecting the power cord. A small click may be heard when power is turned on to the unit. This is normal.

**Important:** All electrical wiring should be free and clear. Wires or cables should not be pinched or otherwise obstructed.

## Installation Instructions (continued)

**IMPORTANT:** If connecting the appliance to a GFCI or AFCI outlet or breaker, the manufacturers recommended use, care, and maintenance schedule for the GFCI/AFCI must be followed.

Improper maintenance can cause the GFCI/AFCI to trip. This will result in the appliance becoming non-operational.

**BlueStar will not be responsible for any service related to improperly maintained GFCI or AFCI circuits.**

Power supply: Grounded, 120VAC, 60Hz

Circuit protection: 15 amp dedicated circuit

**IMPORTANT:** Save these instructions for the local electrical inspector's use.

## Backguard

### **WARNING**

Never obstruct, place anything on top of, or touch the openings in the backguard. This can result in damage to property and objects; fire; serious injury; or death if these precautions are not followed.

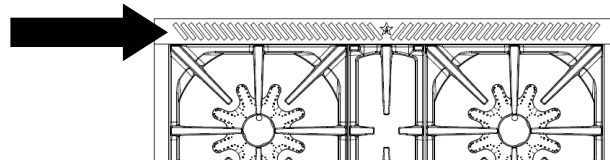

- All ranges and range tops require a backguard to be installed prior to operation.
- Most models have the option of using: island trim (standard); 6 inch, or 24 inch with high shelf.
- All backguards follow the same basic method of installation.
  - The unit must be pulled out of the cabinet to install a backguard
  - Remove grates and existing backguard if present
  - Slide backguard onto the rear of the unit.
  - Align holes and use supplied hardware to fasten the backguard to the unit.
  - A minimum of six sheet metal screws (more depending on the width of the unit) are to be installed, three on each end and more along the bottom edge.
  - Replace removed grates.

# Model Configuration Top Views with Burner Rates

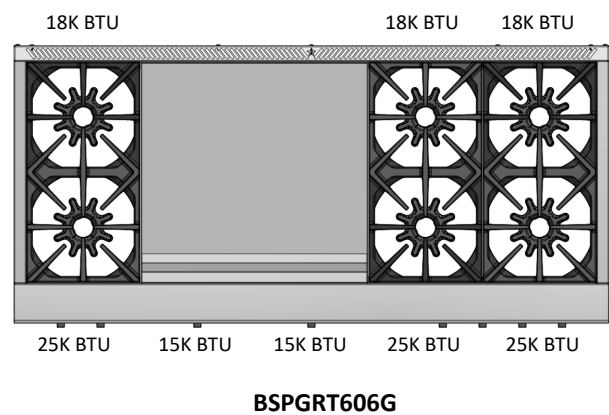
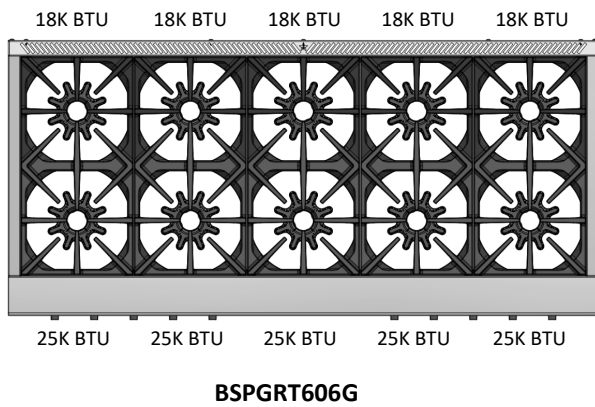
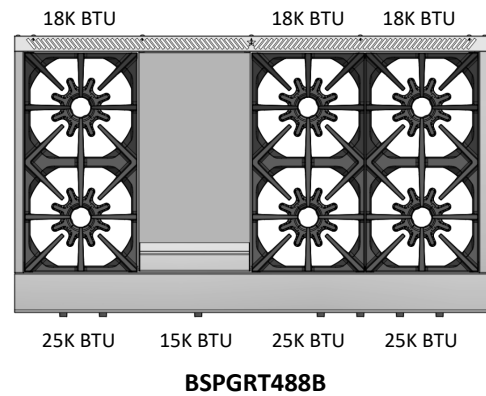
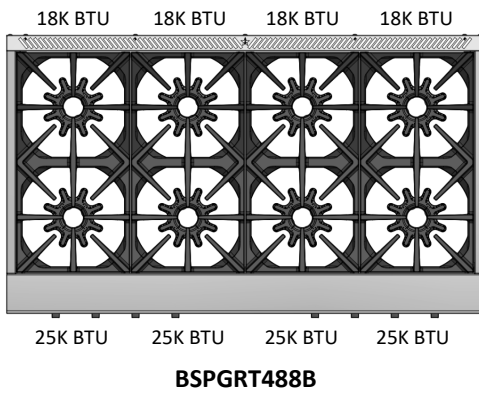
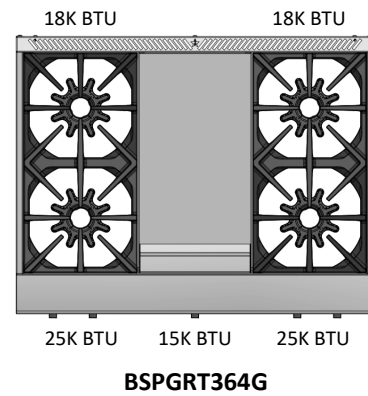
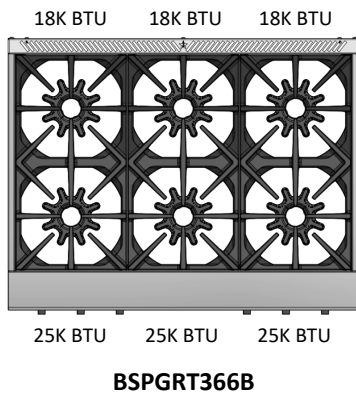
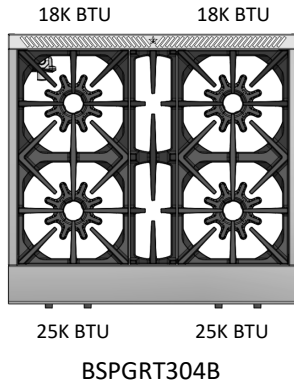

## Operation

### Surface Burners

#### **WARNING**

Lighting the burner in the HIGH position can result in a slight delay of ignition and can produce a large flame. This is normal but not recommended.

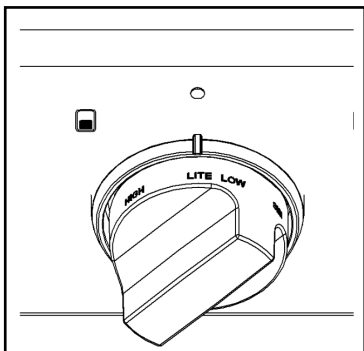

- When turning a burner ON: Push in and turn the burner knob counterclockwise past HIGH to the LITE position to start the ignition process. The ignitor will spark and make a clicking sound which will stop after the burner ignites. After ignition, it may take a few seconds for the gas to reach all the ports.

### Surface Burners

#### **WARNING**

When turning the burner on ALWAYS turn the knob to the LITE position. If the burner is lit in the HIGH position a large flame can result due to the high BTU rate of the burners and varying conditions in the kitchen. Lighting the burner at the LITE position will result in quicker

- After the burner is lit, turn the knob to adjust the flame to your desired setting.
- A white indicator light above each knob indicates the burner is in the ON position.
- Turn the knob to OFF to extinguish the burner. The flame may linger for a few seconds until all the gas in the tube is burned off. Propane units may have an audible popping sounds when the flame extinguishes. This is normal and is caused by the heavier than air property of propane.

### Surface Burners (cont'd)

- Burners have a reignite feature in case the flame is extinguished, however, it may take several seconds for the burner to reignite.
- If a spillover occurs and the flame is extinguished turn the burner OFF, allow the burner to cool and clean the spill and the burner before reusing the burner

**Important:** Never operate the burner with knob set between the HIGH and OFF positions. The flame will not reignite in this position and a gas leak could occur.

### Burner Adjustment

1. After ignition, turn the knob to your desired setting.
2. Each burner has five (5) marked positions:
  - HIGH Maximum heat  
25,000 BTU front burner  
18,000 BTU rear burners
  - LOW Flames will be on all ports at their lowest position.
  - SIM Inner ring of flame only at its highest adjustment.
  - WARM Inner ring of flame only at its lowest adjustment.
3. Turn the knob to OFF to extinguish the burner. The flame may linger for several seconds until all the gas in the burner is burned off.
4. If the burner does not ignite, see the Before Calling for Service section for possible causes and solutions.

**CAUTION:** Never operate the burner with the knob set between the HIGH and OFF position. The flame will NOT re-ignite in this position and a gas leak can occur.

# Cooking Guide and Tips

---

## Burner Settings

1. Burners can be set to any setting between WARM and HIGH.
2. Flames should be adjusted to contact the bottom of the pot and should not extend beyond the edge of any pot or pan.
3. The center ring of flame can be adjusted from WARM to SIM. The difference in the flame is almost not visible despite nearly 1000 BTU difference from lowest to highest adjustment of the ring.

**IMPORTANT:** When set to HIGH, flames should appear as a defined cone with a dark blue center and light blue outside. Some yellow/orange flame may be seen depending on the type of gas and the supply line.

## Simmer Flame

The center ring WARM flame gives you the ability to hold very low settings that can be used to gently melt chocolate and hold delicate sauces and foods at low temperatures.

1. All burners on your range top can turn down to WARM.
2. The LOW setting turns all the ports on the burner to their lowest setting. This setting has been adjusted to hold nearly all foods to a temperature just below boiling. From this setting the flame can be adjusted up all the way to HIGH.

**IMPORTANT:** If a spillover occurs and the center ring flame is extinguished but does not relight it will cause the burner to continuously click and the reignition feature will not function. It is important that the burner be turned off, allowed to cool, then cleaned, taking care to remove any residual food and moisture from the center ring slot.

## Surface Burners

- To avoid oil spillover and fire, use a minimum amount of oil when shallow pan-frying and avoid cooking frozen foods with excessive amounts of ice.
- Never leave the appliance unattended during use. Boil-overs may occur, causing spills which may ignite.
- If you are flaming liquor or other spirits and your appliance is installed under a vent hood, turn off the fan. The draft created could cause the flames to spread out of control.
- Do not use cookie sheets or aluminum foil to cover the grates or line any part of the rangetop. Doing so may result in carbon monoxide build-up and poisoning, over heating the rangetop surfaces, or a potential fire hazard.
- Never leave surface burners unattended. Foods, especially oily foods, may ignite resulting in fire that could spread to surrounding cabinets. Use a deep fry thermometer whenever possible to monitor oil temperature and operate within safe limits.
- To avoid oil spillover and fire, use a minimum amount of oil when shallow pan-frying and avoid cooking frozen foods with excessive amounts of ice.
- If you are flaming liquor or other spirits, turn off the fan on the hood. The draft could cause the flames to spread.
- Do not use cookie sheets or aluminum foil to cover the grates or line any part of the rangetop. Doing so may result in carbon monoxide build-up and poisoning, over heating the rangetop surfaces, or a potential fire hazard.
- Use a deep fry thermometer whenever possible to monitor oil temperature and operate with safe limits.

## Top Grates

When placing the top grate back on the range top, position the silicon feet over the bolt heads securing the porcelain bowl.

**Attention:** Darkening of grates and burners with usage over time is normal.

## Before Your First Use (continued)

### Griddle Seasoning Procedure (select models)

**IMPORTANT:** You must season your griddle before your first use. The seasoning process prevents food from sticking and the surface from rusting. This procedure will take about an hour and a half and you will need to stay and monitor the griddle during this time as the griddle will get very hot!

1. Wipe off any factory oils and residue with a soft cloth.
2. Use a dry cotton towel to apply a light coat of high smoke point oil to the griddle's cooking surface. The smoke point of the oil must be over 450°F (232°C).
3. Use a different dry cotton towel to wipe away excess oil.
4. Push in and turn the griddle burner control knob left to 300°F (149°C) setting and wait 30 minutes.

**CAUTION:** The griddle must be turned on to perform the next steps. Use caution to prevent injury.

5. After 30 minutes, use a dry cotton towel to remove the excess oil from the griddle's surface.
6. Use another clean, dry cotton towel to apply another coat of oil to the griddle's surface.
7. Turn the griddle knob to 325°F (163°C), then wait 15 minutes.
8. Turn the griddle knob to 350°F (177°C), then wait 15 minutes.
9. Turn the griddle knob to 375°F (191°C), then wait 15 minutes.
10. Turn the griddle burner knob back to OFF and taking extreme care, use a clean, dry cotton towel to remove any excess oil while the griddle is hot.

Your griddle is now ready for use. After seasoning, with time and use, your griddle will darken and develop a normal, rich blue/black patina color.

**IMPORTANT:** If food begins to stick to the griddle with use, repeat the seasoning process.

### WARNING

Never obstruct, place anything on top of, or touch the openings in the backguard. This can result in damage to property and objects; fire; serious injury; or death if these precautions are not followed.

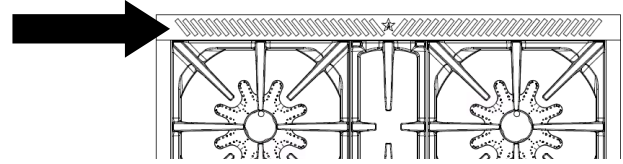

### Griddle (select models)

- Push in and turn the griddle burner knob left to the temperature you want.
- For optimal performance, allow the griddle to preheat for approximately 20-40 minutes before cooking.
- Always leave the grease tray in place while cooking to make cleanup easy.

**IMPORTANT:** To clean your griddle do not scrub the griddle plate with harsh chemicals, or heavy abrasives. This will remove the seasoned finish, which can allow the griddle plate to rust.

To clean the griddle:

- **CAUTION:** Allow the griddle to cool prior cleaning to prevent injury.
- Always leave the grease tray installed when washing your griddle.
- Scrape off as much food residue as possible off the griddle plate using a spatula, scraper, wooden spoon, or a natural bristle brush.
- Use warm soapy water and a soft cloth or sponge to gently wash the griddle plate.
- Use clean water and a soft cloth or sponge to rinse the griddle plate.
- Dry thoroughly using a lint free cloth or paper towel.
- Apply a small amount of vegetable or other neutral cooking oil to the surface of the griddle and wipe across the entire surface to preserve seasoning.

**Important:** Turn off the griddle when you are not using it. Do not bang the griddle with metal utensils as this will damage it.

## Cooking Guide and Tips

---

### Food Safety Tips

Safe steps in food handling, cooking, and storage are essential in preventing food-borne illness. You can't see, smell, or taste harmful bacteria that may cause illness. In every step of food preparation, follow these four guidelines to keep food safe:

- **Clean** – Wash hands and surfaces often.
- **Separate** – Keep raw meat apart from other foods.
- **Cook** – Cook to the right temperature.
- **Chill** – Refrigerate food promptly.

Cook all food to the minimum (see the following page for recommendations from United States Food Safety and Inspection Service) internal temperatures as measured with the temperature probe before removing food from the oven. You may choose to cook food to higher temperatures. A holding temperature of 140°F (60°C) or higher is recommended for food safety.

### High Altitudes

For helpful information on cooking in high altitudes, visit: <https://www.fsis.usda.gov/food-safety/safe-food-handling-and-preparation/food-safety-basics/high-altitude-cooking>.

# Cooking Guide and Tips

## Food Safety Tips

Use the table below as a guideline for internal temperature to safely cook raw meat, poultry, seafood, and other foods. Temperatures should always be checked with a food thermometer to ensure minimum safe internal temperatures have been reached to prevent food poisoning by killing harmful germs.

Resting times are listed for certain foods to allow the innermost parts and juices to fully reach safe temperatures.

Food	Type	Internal Temperature (°F/°C)
Beef, bison, veal, goat, and lamb	Steaks, roasts, chops	145°F (63°C) <b>Rest time: 3 minutes</b>
	Ground meat and sausage	160°F (71°C)
Casseroles	Meat and meatless	165°F (74°C)
Chicken, turkey, and other poultry	All: whole bird, breasts, legs, thighs, wings, ground poultry, giblets, sausage, and stuffing inside poultry.  See USDA's <a href="#">Turkey Thawing Calculator</a> and <a href="#">Turkey Cooking Calculator</a> .	165°F (74°C)
Eggs	Raw eggs	Cook until yolk and white are firm
	Egg dishes (such as frittata, quiche)	160°F (71°C)
	Casseroles (containing meat and poultry)	165°F (74°C)
Ham	Raw ham	145°F (63°C) <b>Rest time: 3 minutes</b>
	Precooked ham (to reheat)	165°F (74°C) <b>Note:</b> Reheat cooked hams packaged in USDA-inspected plants to 140°F (60°C)
Leftovers	Any type	165°F (74°C)
Pork	Steaks, roasts, chops	145°F (63°C) <b>Rest time: 3 minutes</b>
	Ground meat and sausage	160°F (71°C)
Rabbit and venison	Wild or farm-raised	160°F (71°C)
Seafood	Fish (whole or filet), such as salmon, tuna, tilapia, pollock, bass, cod, catfish, trout, etc.	145°F (63°C) or cook until flesh is no longer translucent and separates easily with a fork
	Shrimp, lobster, crab, and scallops	Cook until flesh is pearly or white, and opaque
	Clams, oysters, mussels	Cook until shells open during cooking

**Source:** [FoodSafety.gov](https://www.foodsafety.gov), United States Food Safety and Inspection Service, as of November 21, 2024.

## Care and Cleaning

**Important:** Make sure the appliance is cool before you clean.

Material	Cleaning	Need to Know
Cast Iron	<ul style="list-style-type: none"> <li>Wash in hot, soapy water, rinse well and dry thoroughly. For heavy soiling, use a commercially available oven cleaner. Be sure to follow the cleaner manufacturer's instructions.</li> </ul>	<ul style="list-style-type: none"> <li>Do not allow a commercial oven cleaner to touch painted or stainless steel surfaces.</li> <li>Do not use a wooden or plastic toothpick or any other material that can break to clean burner ports.</li> </ul>
Griddle	<ul style="list-style-type: none"> <li>Wait for it to cool to room temperature and scrape off any excess food with a spatula and wipe off any used cooking oil.</li> <li>For heavy soiling, use a nylon pad coated with a thin layer of cooking oil.</li> <li>For stubborn stains, use a commercially-available, food-safe griddle cleaner. Be sure to follow the cleaner manufacturer's instructions.</li> <li>After every use, apply a light coat of high smoke point oil (like corn oil) to the griddle, then use a clean, dry cotton towel to wipe off the excess.</li> </ul>	<ul style="list-style-type: none"> <li>Do not use soap directly on the griddle surface, residue may remain on the surface of the griddle which can affect the flavor of your food.</li> <li>Never flood a hot griddle plate with cold water.</li> <li>Do not allow your griddle to stand without a fresh coat of oil.</li> </ul>
Porcelain-Coated Burner Bowl	<ul style="list-style-type: none"> <li>Wash with hot, soapy water, rinse well and dry thoroughly.</li> </ul>	<ul style="list-style-type: none"> <li>Do not use steel wool or metal pads as they may damage or scratch the enamel coating.</li> <li>Do not permit citrus or tomato juices to sit and dry on these surfaces as citric acid will discolor the surface. Wipe such spills immediately.</li> </ul>
Stainless Steel	<ul style="list-style-type: none"> <li>Clean with stainless steel cleaner and follow the cleaner manufacturer's instructions.</li> </ul>	<ul style="list-style-type: none"> <li>Do not use steel wool, metal pads, or abrasive cleaners.</li> <li>Do not use a metal knife, spatula, or any metal tool to scrape these surfaces.</li> <li>Do not permit citrus or tomato juices to sit and dry on these surfaces as citric acid will discolor the surface. Wipe such spills immediately.</li> <li>Do not polish across the grain or in circles.</li> <li>Discoloration may occur with heavy use.</li> </ul>
Painted Metal	<ul style="list-style-type: none"> <li>Use a soft cloth and a quality glass cleaner or warm soapy water.</li> </ul>	<ul style="list-style-type: none"> <li>Do not use steel wool, metal pads, or abrasive cleaners.</li> <li>Do not use a metal knife, spatula, or any metal tool to scrape these surfaces.</li> <li>Do not permit citrus or tomato juices to sit and dry on these surfaces as citric acid will discolor the surface. Wipe such spills immediately.</li> <li>Do not use paper towels or other coarse cloths.</li> </ul>
Top Burners	<ul style="list-style-type: none"> <li>Use a soft cloth or sponge and warm soapy water</li> <li>Clear any blocked ports with a thin toothpick or skewer</li> </ul>	<ul style="list-style-type: none"> <li>Do not use chlorine or other harsh chemical cleansers</li> <li>Do not use steel wool, metal pads, or abrasive cleansers</li> <li>Do not use a metal knife, spatula, or any metal tool to scrape these surfaces</li> </ul>

## Care and Cleaning (continued)

Material	Cleaning	Need to Know
Plated Finishes (Brass, Copper, Chrome, Oil-Rubbed Bronze, Pewter)	<ul style="list-style-type: none"><li>• The parts were treated with a protective clear coat to prevent aging or discoloration. This clear coat will last the life of the appliance unless the coating is removed.</li><li>• Clean with a microfiber cloth using Endust, Pledge, or something similar.</li></ul>	<ul style="list-style-type: none"><li>• Do not use a metal knife, spatula, or something similar or any metal tool to scrape these surfaces.</li><li>• Do not permit citrus or tomato juices to sit and dry on these surfaces as citric acid will discolor the surface. Wipe such spills immediately.</li><li>• Do not use harsh cleaners (such as Brite Boy) as these will remove the coating and cause the metals to discolor.</li></ul>

# Troubleshooting

Check these helpful tips for any problems with your oven. If additional help or service is needed, please call customer service at (800) 449-8691. You will need to have the model and serial numbers for your appliance ready before you contact them. See Product Information on page 4 for information on finding these numbers.

Problem	Possible Cause	Solution
Burner will not ignite and there is no "clicking" sound	<ul style="list-style-type: none"> <li>• No electrical power to the appliance.</li> <li>• Poor ground connection</li> <li>• Electric polarity is reversed</li> </ul>	<ul style="list-style-type: none"> <li>• Plug into a properly grounded three-prong electrical outlet.</li> <li>• Check and reset the circuit breaker for the appliance.</li> </ul>
Burner will not ignite and there is a "clicking" sound, but no spark	<ul style="list-style-type: none"> <li>• Gas is not turned on.</li> <li>• Clogged burner ports.</li> <li>• Dirty electrode</li> </ul>	<ul style="list-style-type: none"> <li>• Turn on the gas supply.</li> <li>• Use a push pin or safety pin to clear the ports.</li> </ul>
Burner will not ignite and there is a "clicking" sound and a spark	<ul style="list-style-type: none"> <li>• Gas is not turned on.</li> <li>• The center flame ring slot is clogged.</li> </ul>	<ul style="list-style-type: none"> <li>• Turn on the gas supply.</li> <li>• Clean the burner and clear any food or moisture trapped in the center flame ring slot.</li> </ul>
Burner ignites but the "clicking" sound does not stop	<ul style="list-style-type: none"> <li>• Burners are wet.</li> <li>• Electric plug is not in grounded outlet.</li> </ul>	<ul style="list-style-type: none"> <li>• Let burners dry and try again.</li> <li>• Check the outlet polarity.</li> <li>• Plug the appliance into a grounded three-prong electrical outlet.</li> </ul>
Burner does not fully ignite	<ul style="list-style-type: none"> <li>• Partial gas supply.</li> <li>• Clogged burner ports.</li> </ul>	<ul style="list-style-type: none"> <li>• Make sure the gas supply is fully on.</li> <li>• Use a push pin or safety pin to clear the ports.</li> </ul>
Burner flame floats	<ul style="list-style-type: none"> <li>• For LP users—the propane supply is low.</li> <li>• Burner is dirty and ports are clogged.</li> </ul>	<ul style="list-style-type: none"> <li>• Fill the propane tank.</li> <li>• Clean burners and burner ports.</li> </ul>

# Warranty

---

Prizer-Painter Stove Works, Inc. ("Prizer-Painter") warrants your BlueStar appliance ("product") purchased in the U.S. and Canada and installed in residential properties for normal residential use.

## What Is Covered

Subject to the specific conditions and limitations below, this warranty covers parts and/or labor necessary to repair or replace any part of the product that contains defects in materials and workmanship.

**Two Year Warranty.** For two (2) years from the date of installation, this warranty covers all parts and labor necessary to repair or replace any part on the product except for the Cosmetic Component Warranty below.

**Cosmetic Component Warranty.** For thirty (30) days from the date of installation, this warranty covers scratches and dents, paint and porcelain blemishes, visible chips, etc.

## Limitations of Coverage

- Floor Models. For one (1) year from the date of installation, this warranty covers all parts and labor necessary to repair or replace any part on the product except for cosmetic parts for which there is no warranty.
- The replacement of a part under this warranty does not extend the warranty period.
- Warranty service outside normal business hours and in areas beyond 50 miles one way from an authorized BlueStar retailer or service provider. The owner will be responsible for any and all costs associated with additional mileage, non-standard service or overtime, and special equipment required to remove the product so service may be performed.

This warranty is void:

- If the product is removed from where it was originally installed.
- If the original factory installed serial number is altered or removed from the product.
- If gas cooking products are converted by someone other than a BlueStar authorized service company.

## What Is Not Covered

This warranty does not cover, and specifically excludes:

- Product installed or used in any commercial or other non-residential property such as, but not limited to, day care facilities, fire stations, hotels, nursing homes, etc.
- Installation related issues including or installation inconsistent with the product specifications/ installation instructions.
- Damage or repairs caused by alterations or modifications, abuse, misuse, neglect, or improper installation, mounting, handling, operation, maintenance, or storage.
- Normal adjustments after installation and setup.
- Normal wear, care, and maintenance of the product as described in this manual.
- Service calls to educate the customer on the proper use and care of the product.
- Consumable parts.
- Damage or repairs caused by unauthorized service or repairs, including unauthorized adjustments or calibrations performed on the product.
- Accidental or intentional damage.
- Damage or repairs as a result of natural disasters, fires, floods, earthquakes, winds, lightning, corrosive atmosphere, loss of electrical power to the product for any reason, or other conditions beyond Prizer-Painter's control.
- Damage or repairs caused by alteration for outdoor use.
- Damage or repairs caused by the use of harsh chemicals or cleaning products improperly applied.
- Damage to surrounding property including cabinetry, floors, ceilings, etc.
- Consequential or incidental damage, including but not limited to food or medicine loss, time away from work, restaurant meals, etc.

The terms of this warranty provide for repair of the product only. If the product cannot be repaired, Prizer-Painter, at its sole discretion, will determine whether to exchange the product.

Please see the Arbitration Clause and Related Provisions, which affect your legal rights. The Arbitration Clause is available at [www.bluestarcooking.com](http://www.bluestarcooking.com).

