

BlueStar® has combined professional level features and a sleek design into its new Sealed Burner Series. Cook like a pro with professional level power and versatility with up to 21,000 BTUs* of searing power plus a precise simmer burner. The Sealed Burner Series features an extra-large convection oven that will accommodate a commercial size baking sheet.

PRODUCT FEATURES

- Sealed burner design with up to 21,000 BTUs of power *
- Precise simmer burner
- Extra-large convection oven with 1850° infrared broiler that accommodates a full size 18" x 26" commercial baking sheet
- 24" depth for compatibility with standard kitchen cabinetry
- Includes standard island trim backguard
- Available in stainless steel
- Handcrafted in Pennsylvania since 1880

SPECIFICATIONS

Range Dimensions: 29.875"W x 24"D x 36.75"H
 Oven Interior: 26.25"W x 20"D x 15"H
 Top Burner Rating: Nat: 21,000 BTUs | LP: 18,000 BTUs
 Simmer Burner Rating: 5,000 BTUs
 Large Oven Burner Rating: 30,000 BTUs
 Infrared Broiler Rating: 15,000 BTUs
 Electrical Requirements: 120V, 60Hz, 15 AMPs, 1 PH
 (Unit must be on a Non-GFI, dedicated outlet)
 Operating Gas Pressure: NAT: 5.0" WC, LP: 10.0" WC
 Gas Line Size: 1/2"
 Installation Clearance: 0" Side Cabinet, 0" Back Wall



MODEL CONFIGURATION

Four Burners

RCS30SBV2

BURNER CONFIGURATION

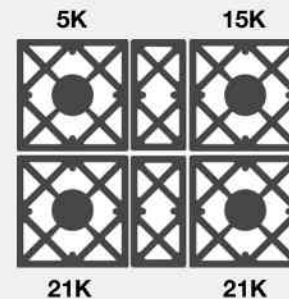

ADDITIONAL CUSTOMIZATION OPTIONS

- Backguards
- Knob colors
- Trim options

All specifications subject to change without notice. Visit www.bluestarcooking.com prior to installation or site preparation.

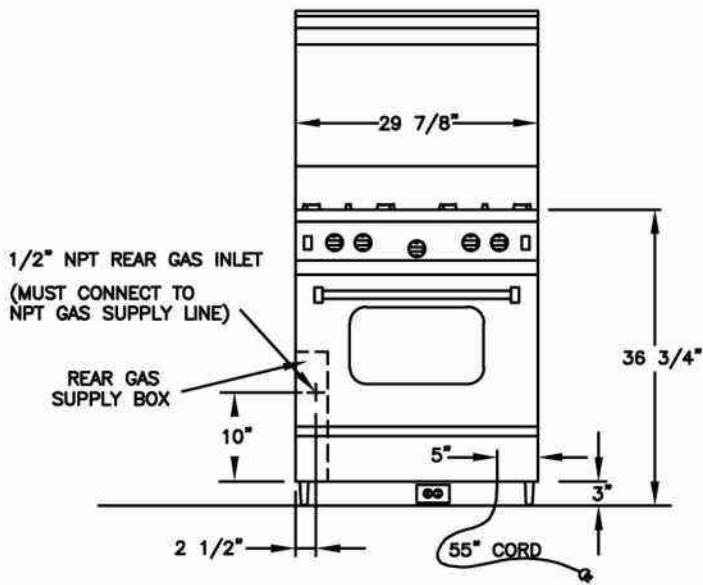

ELECTRICAL CORD LOCATED IN BACK OF UNIT
 LOCATION OF ELECTRICAL OUTLET MUST
 NOT BE HIGHER THAN 3" FROM FLOOR IF LOCATED BEHIND
 THE UNIT OR CAN BE LOCATED IN AN ADJOINING CABINET.

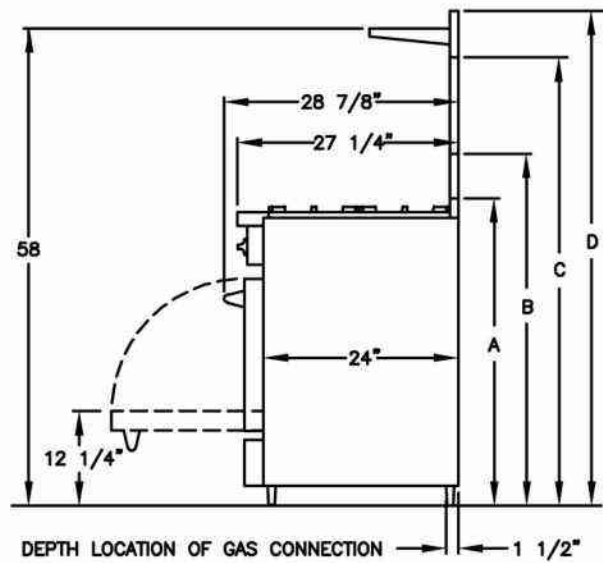

- A - ISLAND TRIM HEIGHT - 38 1/4"
- B - 6" STANDARD BACKGUARD HEIGHT - 43 1/4"
- C - 17" BACKGUARD HEIGHT - 54 1/4"
- D - HIGH SHELF BACKGUARD HEIGHT - 61"

RELATED PRODUCTS

VENTILATION

