

New features found only on the Platinum Series offer unsurpassed power and performance for discerning home chefs who demand restaurant-quality results.



PRODUCT FEATURES

- PrimaNova™ power burner delivers 25,000 BTUs of intense heat
- All burners including Interchangeable Griddle and Charbroiler
- Gentle 130° simmer burner
- New PowR Oven™ provides 40% faster preheating and 30% increase in oven efficiency
- Extra-large oven with True European Convection 1850° Infrared Broiler
- Accommodates full-size commercial 18" x 26" baking sheet
- Available in 1,000+ colors and finishes

SPECIFICATIONS

Range Dimensions: 47.875"W x 24"D x 36.75"H
 Large Oven Interior: 26.438"W x 20"D x 15"H
 Small Oven Interior: 13.578"W x 20"D x 15"H
 Top Burner Rating: 25,000 BTUs
 Simmer Burner Rating: 9,000 BTUs
 PowR Oven™ Burner Rating: 25,000 BTUs
 Infrared Broiler Rating: 15,000 BTUs
 Electrical Requirements: 120V, 60Hz, 15 AMPs, 1 PH (Unit must be on a Non-GFI, dedicated outlet)
 Operating Gas Pressure: NAT: 5.0" WC, LP: 10.0" WC
 Gas Line Size: 3/4"
 Installation Clearance: 0" Side Cabinet, 0" Back Wall

MODEL CONFIGURATION

Eight Burners with Interchangeable Griddle Charbroiler **BSP488B**

BURNER CONFIGURATION

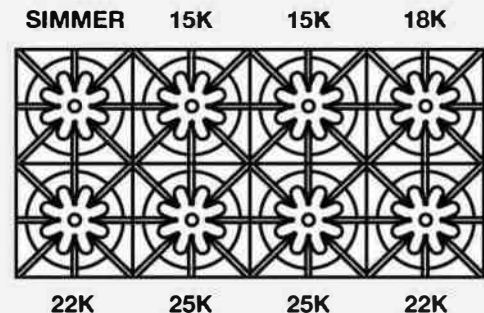

ADDITIONAL CUSTOMIZATION OPTIONS

- Burner configurations
- Backguards
- Knob colors
- Trim options

All specifications subject to change without notice. Contact BlueStar Customer Service at (800) 449 - 8691 prior to installation or site preparation.

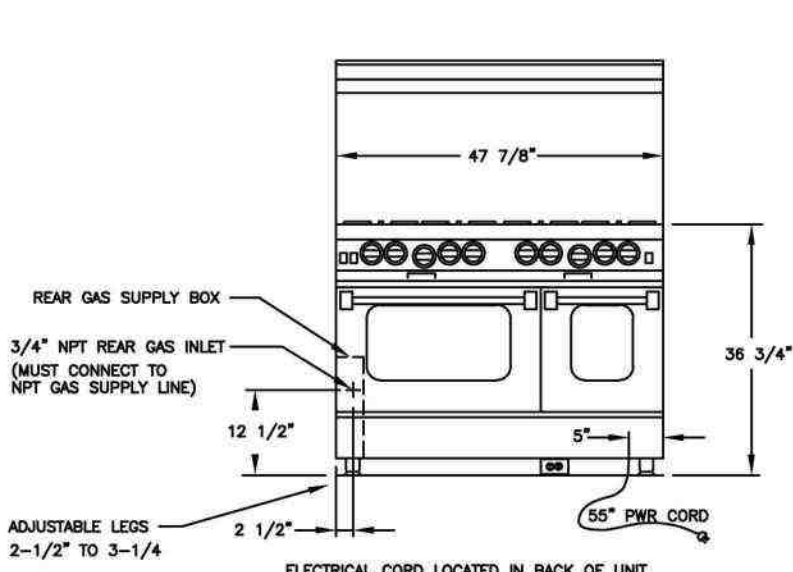

ELECTRICAL CORD LOCATED IN BACK OF UNIT
 LOCATION OF ELECTRICAL OUTLET MUST
 NOT BE HIGHER THAN 3" FROM FLOOR IF LOCATED BEHIND
 THE UNIT OR CAN BE LOCATED IN AN ADJOINING CABINET.

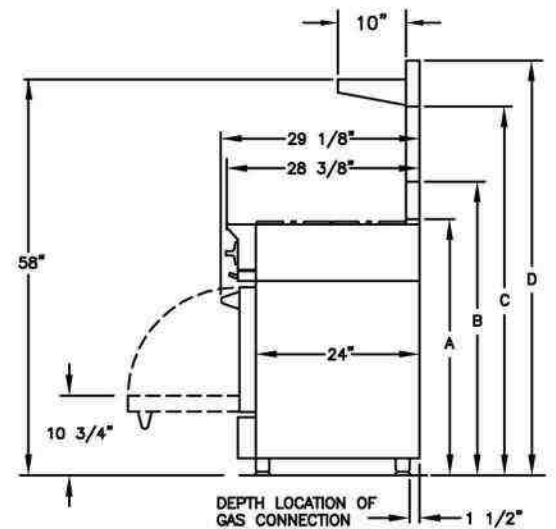

- A - ISLAND TRIM HEIGHT - 37 1/2"
- B - 6" STANDARD BACKGUARD HEIGHT - 43"
- C - 17" BACKGUARD HEIGHT - 54"
- D - HIGH SHELF BACKGUARD HEIGHT - 60 3/4"

RELATED PRODUCTS

VENTILATION



SALAMANDER BROILER

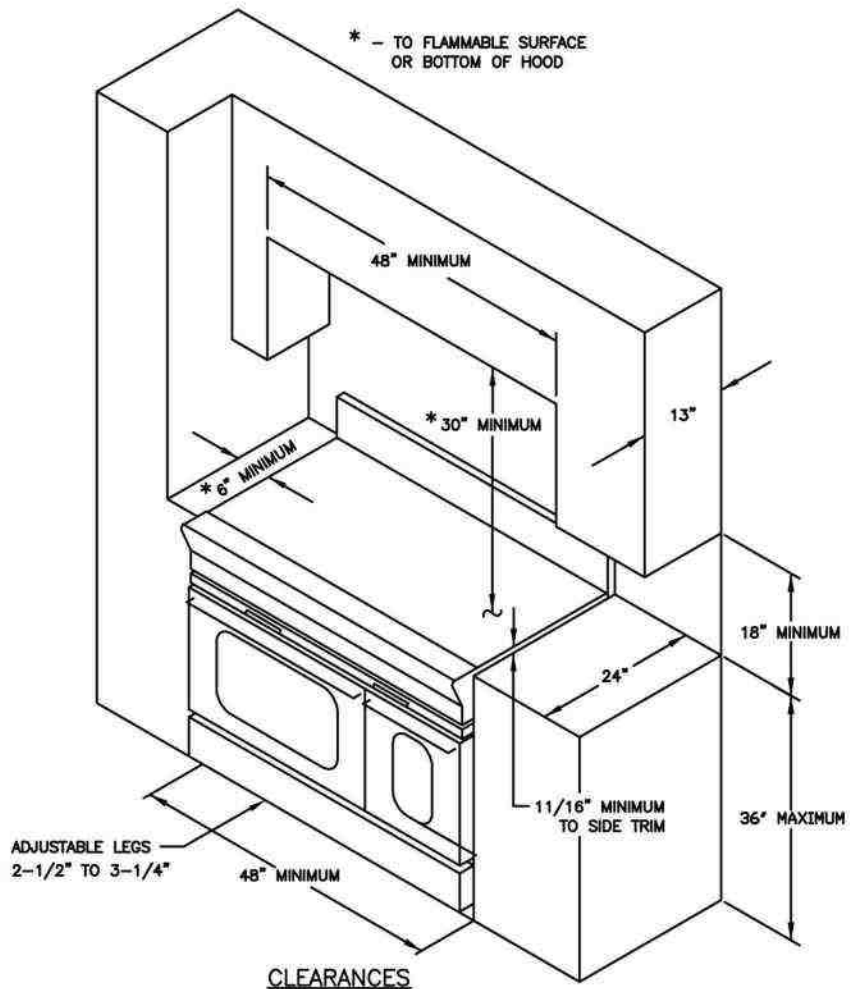

CLEARANCES