

New features found only on the Platinum Series offer unsurpassed power and performance for discerning home chefs who demand restaurant-quality results.



PRODUCT FEATURES

- PrimaNova™ power burner delivers 25,000 BTUs of intense heat
- All burners plus Interchangeable Griddle Charbroiler system
- Gentle 130° simmer burner
- Integrated wok cooking
- Full motion grates
- Refined design and easier-to-clean cooktop
- 24" depth for compatibility with standard kitchen cabinetry

SPECIFICATIONS

Rangetop Dimensions: 35.875"W x 24"D x 8.625"H

Top Burner Rating: 25,000 BTUs

Simmer Burner Rating: 9,000 BTUs

Electrical Requirements: 120V, 60Hz, 15 AMPs, 1 PH
(Unit must be on a Non-GFI, dedicated outlet)

Operating Gas Pressure: NAT: 5.0" WC, LP: 10.0" WC

Gas Line Size: 1/2"

Installation Clearance: 0" Side Cabinet, 0" Back Wall

MODEL CONFIGURATION

Six Burners

BSPRT366B

BURNER CONFIGURATION

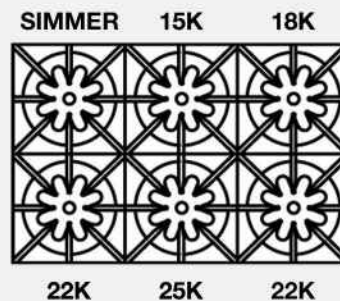

ADDITIONAL CUSTOMIZATION OPTIONS

- Burner configurations

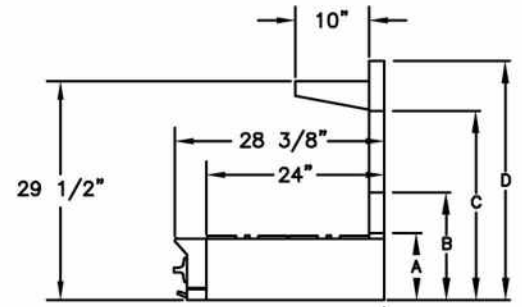
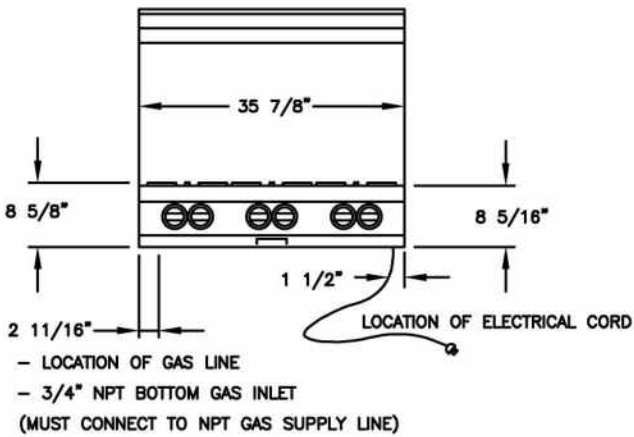

LOCATION OF ELECTRICAL CONNECTION
 NOTE: A HOLE MUST BE DRILLED INTO THE BASE CABINET TO ACCEPT ELECTRICAL CORD.

LOCATION OF GAS LINE
 NOTE: A HOLE MUST BE DRILLED INTO THE BASE CABINET TO ACCEPT GAS LINE.

- A - ISLAND TRIM HEIGHT - $9 \frac{1}{16}$ "
- B - 6" STANDARD BACKGUARD HEIGHT - $14 \frac{9}{16}$ "
- C - 17" BACKGUARD HEIGHT - $25 \frac{9}{16}$ "
- D - HIGH SHELF BACKGUARD HEIGHT - $32 \frac{5}{16}$ "

RELATED PRODUCTS

VENTILATION



SALAMANDER BROILER

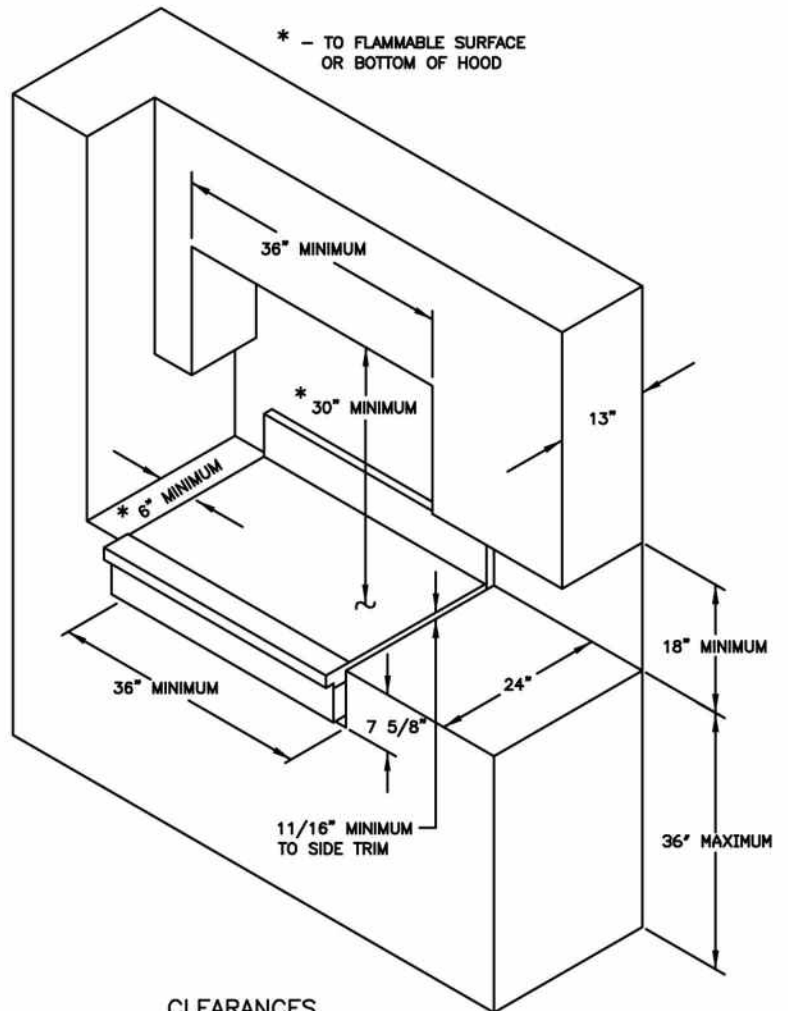

CLEARANCES