

USE AND CARE MANUAL



BLUESTAR[®]

**BUILT-IN BOTTOM
FREEZER REFRIGERATOR**

Contents

Features	5
Electronic Controls	6
Refrigerator Features	7
Freezer Features	9
Operation	10
Care and Cleaning	12
Troubleshooting	13
Warranty	14

Model Information

The model and serial numbers are located on the serial plate, which is located in the refrigerator on the left side behind the pull-out tray. Please complete the information below for future reference and warranty purposes:

Model Number _____

Serial Number _____

Installation Date _____

Dealer's Name _____

Dealer's Phone Number _____

For authorized service, please call 877.427.3290. Warranty service must be performed by authorized service. BlueStar also recommends using authorized service if service is required after the warranty expires.

Safety Information

Please read and obey the following types of safety messages to ensure your refrigerator is installed and operated as safely as possible:

DANGER

Will cause serious injury or death if instructions are not followed.

WARNING

Can cause serious injury or death if instructions are not followed.

CAUTION

Can cause minor injury or product damage if instructions are not followed.

WARNING

Electrical Shock Hazard

Follow these basic precautions:

- Plug into a grounded three-prong outlet.
- Do not remove ground prong.
- Do not use an adapter.
- Do not use an extension cord.
- Disconnect power before servicing.
- Replace all parts and panels before operating.
- Remove doors from your old refrigerator.
- Use nonflammable cleaner.
- Keep flammable materials and vapors, such as gasoline, away from refrigerator.
- Use two or more people to move and install refrigerator.

Failure to follow these instructions can result in death, electrical shock, or fire.

Renseignements sur la sécurité

Veillez lire et observer les types suivants de messages de sécurité pour vous assurer que votre réfrigérateur est installé et utilisé de la façon la plus sécurisée possible :

DANGER

Provoque des blessures graves, voire la mort, si les instructions ne sont pas observées.

AVERTISSEMENT

Peut entraîner des blessures graves, voire la mort, si les instructions ne sont pas observées.

MISE EN GARDE

Peut entraîner des blessures légères ou des dommages sur produit si les instructions ne sont pas observées.

AVERTISSEMENT

Risque de choc électrique

Observer les précautions de base suivantes

- Brancher l'appareil à une prise triphasée mise à la terre.
- Ne pas retirer la broche de mise à la terre.
- Ne pas utiliser d'adaptateur.
- Ne pas utiliser de rallonge.
- Débrancher l'alimentation avant l'entretien.
- Remettre en place toutes les pièces et tous les panneaux avant d'utiliser le produit.
- Déposer les portes de votre ancien réfrigérateur.
- Utiliser un nettoyeur ininflammable.
- Garder les matières et les vapeurs inflammables, comme l'essence, à l'écart du réfrigérateur.
- Deux personnes ou plus doivent déplacer et installer le réfrigérateur.

Le non-respect de ces instructions peut entraîner la mort, un choc électrique ou un incendie.

Safety Information

⚠ DANGER

Suffocation Hazard

Remove doors from old refrigerators. Failure to follow these instructions can cause death or brain damage.

Important: Child entrapment and suffocation are not problems of the past. Junked or abandoned refrigerators are still dangerous even if they will sit for a few days. Before you throw away your old refrigerator or freezer, do the following:

- Take off the doors.
- Leave the shelves in place so that children may not easily climb inside.

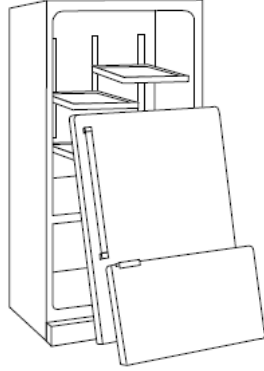

Renseignements sur la sécurité

⚠ DANGER

Risque d'étouffement

Déposer les portes des anciens réfrigérateurs. Le non-respect de ces instructions peut entraîner la mort ou des lésions cérébrales.

Important : Le coincement et l'étouffement des enfants ne sont pas des problèmes du passé. Les réfrigérateurs mis au rebut ou abandonnés restent dangereux même s'ils doivent reposer pendant quelques jours. Avant de jeter votre ancien réfrigérateur ou congélateur, observez les consignes suivantes:

- Déposer les portes.
- Laisser les étagères en place pour que les enfants ne puissent pas grimper facilement à l'intérieur.

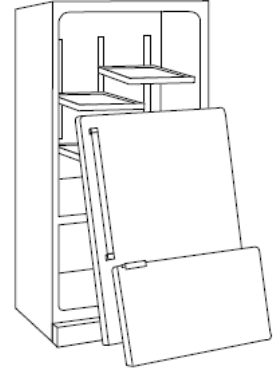

Features

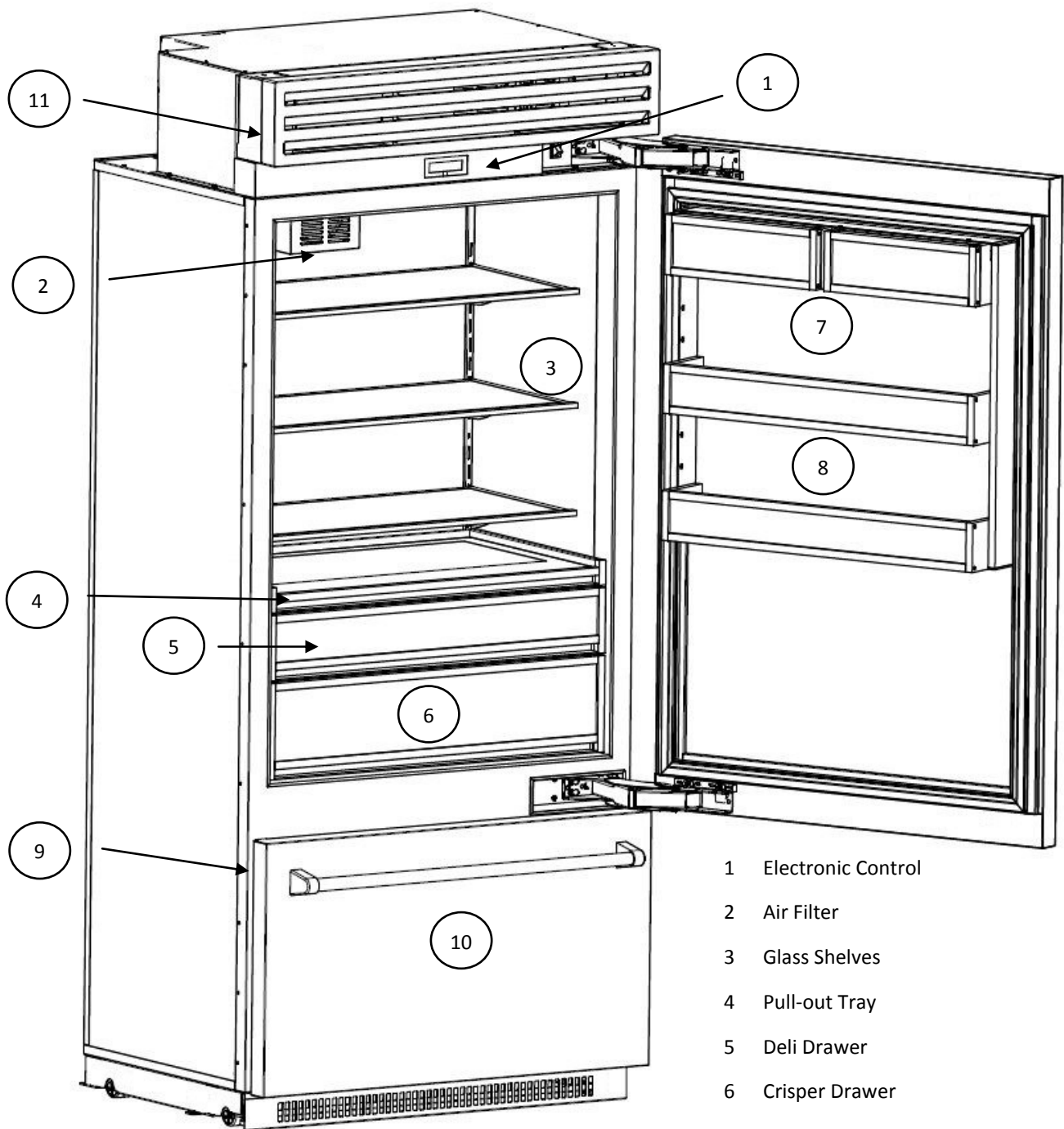

- 1 Electronic Control
- 2 Air Filter
- 3 Glass Shelves
- 4 Pull-out Tray
- 5 Deli Drawer
- 6 Crisper Drawer
- 7 Dairy Bins
- 8 Door Bins
- 9 Ice Maker
- 10 Freezer Bins
- 11 Water Filter (behind top grille)

Electronic Control

Home Screen

Displays the freezer and refrigerator temperatures.

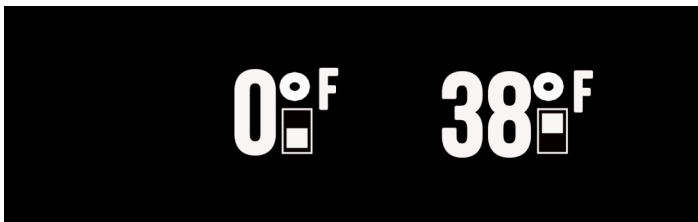

Change Temperature Setting

Press and hold either the refrigerator or freezer temperature setting for two seconds. After two seconds, the control will display the temperature setting with up and down arrows. Press the up or down arrow to establish the new temperature setting. Press and hold the new setting for two seconds to confirm it. Once the new setting is confirmed, the control will default to the home screen.

Refrigerator

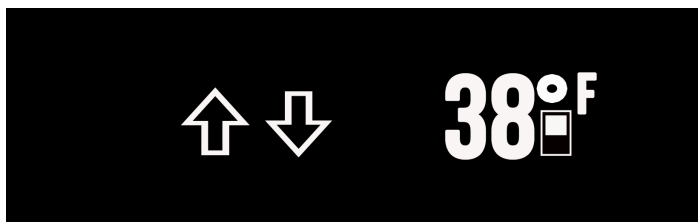

Freezer



Main Options

Swipe right or left to access the main options.

Max Ice



Increases ice production by 50%. Returns to normal ice production after 24 hours. When Max Ice is activated, the icon is illuminated.

Water Filter



Resets the water filter. Press and hold for two seconds to reset the filter. The remaining percentage is displayed to the right of the icon.

Sabbath Mode



Enables or disables Sabbath mode. Press and hold for two seconds to enable Sabbath mode. When Sabbath mode is enabled, the home screen will display the icon. Press and hold for two seconds to disable Sabbath mode.

Settings



Accesses the settings options.

Setting Options

Ice Maker



Turns the ice maker off or on. The ice maker is shipped on with the bale arm on the ice maker in the on (lowest) position. When the ice maker is on, the icon is illuminated.

Alarm



Turns the audible door and high temperature alarm off or on.

Fahrenheit or Celsius



Changes the temperature scale. Press to toggle between Fahrenheit and Celsius. The selected scale is illuminated.

Electronic Control

Alarms

Door Alarm

Sounds continuously when the refrigerator or freezer door is open for more than five minutes. Shut the refrigerator or freezer door to stop the alarm.

High Temperature Alarm

Sounds continuously when either the refrigerator temperature exceeds 50° or the freezer exceeds 20° for more than three hours. The home screen will flash a series of dashes in place of the refrigerator and/or freezer temperature until the temperature reaches the set temperature.

Service

The electronic control continually manages the refrigerator's operating system. If there is an issue with the operating system, the home screen will display "Call for Service" and a series of dashes will flash in place of the refrigerator and freezer temperatures. Please call 877.427.3920 to schedule a service call.

Refrigerator Features

Important Information

Glass shelves and drawers are heavy as they are made of glass and metal. Use special care when removing them to avoid impact from dropping.

Glass Shelves

These spill proof shelves adjust to meet individual needs and create an invisible barrier to contain spills.

Important Information

Do not clean glass with warm water when it is cold. Glass may break if exposed to sudden temperature changes or impact, such as bumping. For your protection, tempered glass is designed to shatter into many small, pebble-size pieces, which is normal.

- **Remove:** Lift the front of the shelf with one hand while supporting the back with the other hand. Lift the back of the shelf out of the shelf support. Pull the shelf straight out.

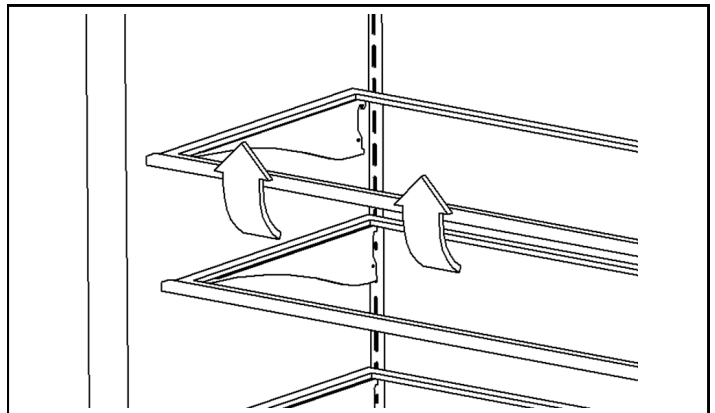

- **Replace:** Guide the rear shelf hooks into the shelf supports. Tilt the front of the shelf up until the rear shelf hooks drop in the shelf supports. Lower the front of the shelf and check to make sure that the shelf is securely in position.

Refrigerator Features

Pull-Out Tray

- **Remove:** Pull the tray forward until it stops. Remove the glass by lifting it from underneath the tray. Remove the Phillips screws from both sides of the tray (near the front). Slide the tray forward to release it from the rear hooks on the slides.
- **Replace:** Extend the slides. Align the tray on the slides and push back until the tray engages the rear hooks on the slides. Replace the Phillips screws on both sides of the tray (near the front). Do not over-tighten the screws. Set glass on top of the tray.

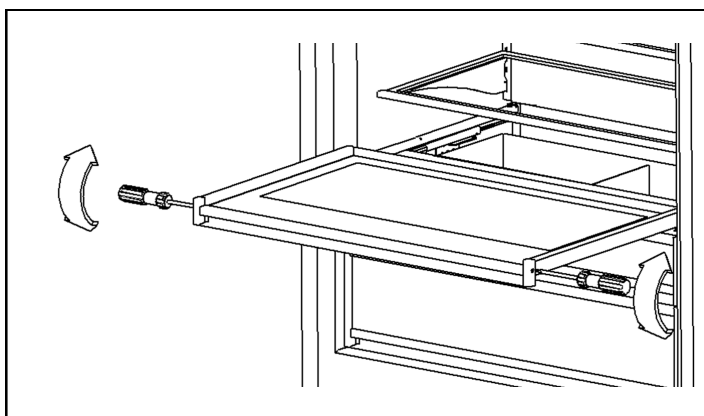

Deli and Crisper Drawers

- **Remove:** Pull the drawer forward until it stops. Remove the Phillips screws from both sides of the drawer (near the front). Slide the drawer forward to release it from the rear hooks on the slides.
- **Replace:** Extend the slides. Align the drawer on the slides and push back until the drawer engages the rear hooks on the slides. Replace the Phillips screws on both sides of the drawer (near the front). Do not over-tighten the screws.

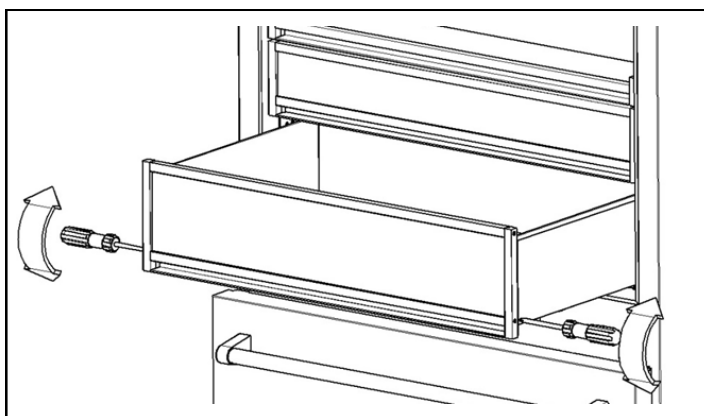

Dairy and Door Bins

- **Remove:** Lift the bin up and pull it out.
- **Replace:** Place the bin over the pegs in the door and lower it in place. Check to make sure the bin is securely in position.

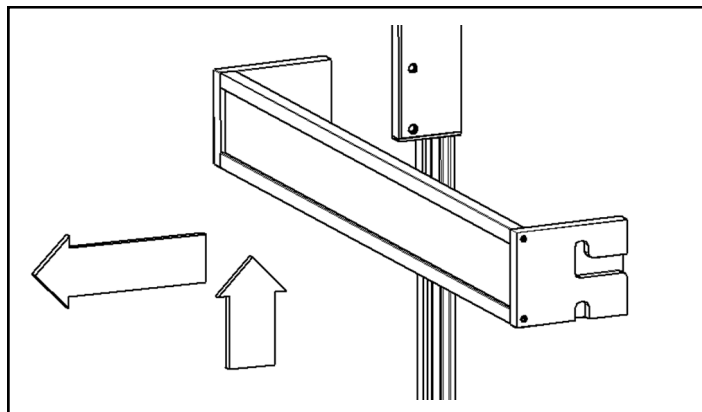

If placing a door bin in the lowest position, confirm the two pegs are engaged on each side and the bottom of the door bin does not hang below the side walls.

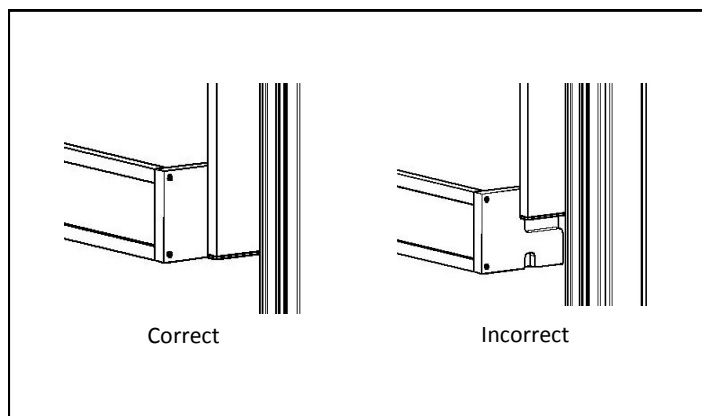

Freezer Features

Upper Drawer

Important Information

Drawers are heavy as they are made of metal. Use special care when removing them to avoid impact from dropping.

- **Remove:** Pull the drawer forward until it stops. Remove the Phillips screws from both sides of the drawer (near the front). Slide the drawer forward to release it from the rear hooks on the slides.
- **Replace:** Extend the slides. Align the drawer on the slides and push back until the drawer engages the rear hooks on the slides. Replace the Phillips screws on both sides of the drawer (near the front). Do not over-tighten the screws.

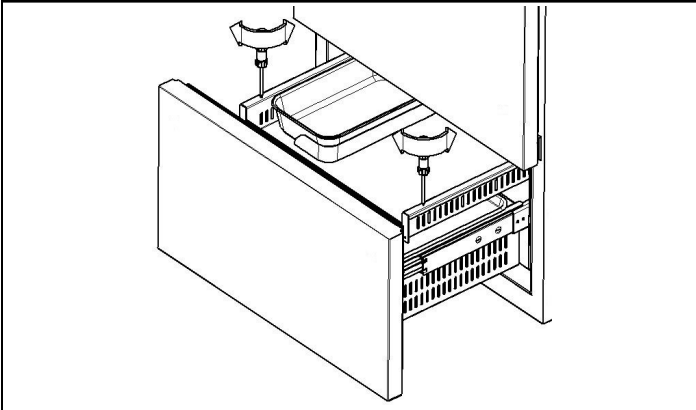

Ice Maker

The ice maker will produce approximately 2 1/2 pounds of ice every 24 hours.

When the refrigerator is shipped, the ice maker setting in the electronic control is on and the bale arm on the ice maker is in the on (lowest) position. **Both the electronic control and the bale arm must be on for the ice maker to produce ice.**

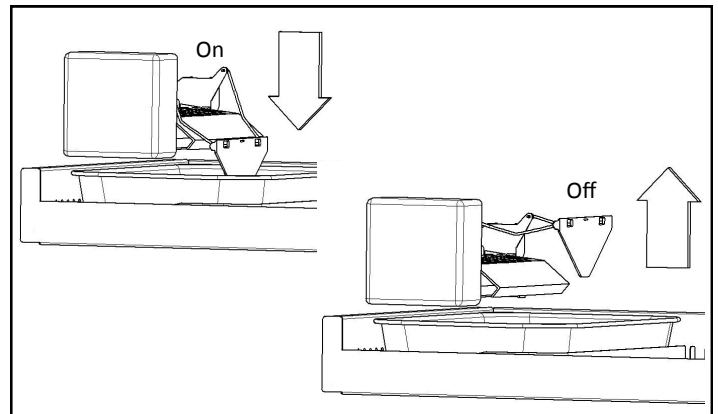

After initially connecting the ice maker to the water line, discard the first two full pans of ice as the ice may contain air or impurities from the water line.

Operation

Top Grille

The top grille lifts up for easy access to the power switch (on the right) and the water filter (on the left). Lift the top grille by pulling out the bottom edge of the grille and rotating it upwards.

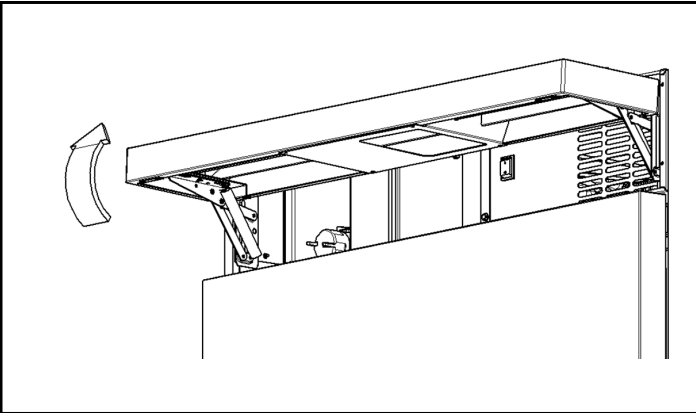

Power Switch

The power switch turns your refrigerator off or on.

Water Filter

⚠ WARNING

To reduce the risk associated with the ingestion of contaminants, **DO NOT** use with water that is microbiologically unsafe or of unknown quality without adequate disinfection before or after the system. Systems certified for cyst reduction may be used on disinfected water that may contain filterable cysts.

EPA Establishment 070595-MEX-001.

⚠ AVERTISSEMENT

Pour réduire le risque lié à l'ingestion de contaminants, **NE PAS** utiliser une eau qui ne soit pas sûre d'un point de vue microbiologique ou dont la qualité est inconnue sans une désinfection adéquate avant ou après le système. Les systèmes certifiés en matière de réduction des kystes peuvent être utilisés pour l'eau désinfectée qui peut contenir des kystes filtrables.

Établissement EPA 070595-MEX-001.

The water filter, AP2-200G, supplies filtered water to the ice maker and is located behind the top grille. The filter is rated for 200 gallons or six months, whichever comes first.

A copy of the water filter data sheet is included with the filter and can also be found at bluestarcooking.com.

When using the water filter for the first time, discard the first two full pans of ice as the ice may contain air or impurities from the water line.

Operation

Replacement Filters

Important Information

Read and follow instructions before installation and use of this system. Change the water filter at the recommended interval; the water filter **MUST** be replaced every six months or sooner. Failure to replace the water filter at the recommended intervals may lead to reduced water filter performance and failure of the water filter, causing property damage from water leakage or flooding.

Replacement filters can be ordered at bluestarcooking.com or by calling customer service at 877.427.3920.

When the water filter needs to be replaced, the home screen will display the water filter icon until the water filter is reset.

1. Lift up the top grille to access the water filter.

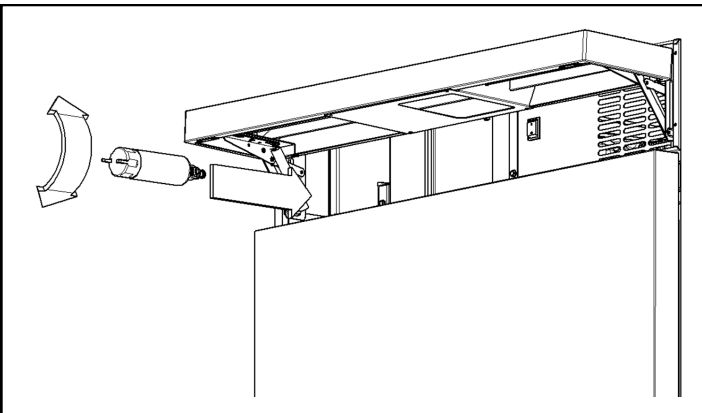

2. Rotate the old filter counterclockwise a half turn and pull out. It is normal for a small amount of water to drip when the filter is removed. Wipe it up with a cloth or paper towel.
3. Remove the filter from the packaging.
4. Insert the new filter and rotate it clockwise a half turn.
5. Lower the top grille.
6. Press and hold the water filter icon on the main options screen for two seconds to reset the water filter.
7. Discard the first two full pans of ice as the ice may contain air or impurities from the water line.

If the water filter will not be used, a bypass plug is not necessary as there is an internal bypass circuit, which eliminates the need for a separate plug.

Air Filter

The air filter is located in the fan cover on the back wall of the refrigerator and is rated for six months.

- **Remove:** Pull the tab on the filter towards the right.
- **Replace:** Remove the filter from the packaging. Align the filter with the opening and slide it into the fan cover.

Replacement filters can be ordered at bluestarcooking.com or by calling customer service at 877.427.3920.

Lighting

Interior lighting in the refrigerator, deli and crisper drawers, and freezer is provided by LEDs. In the event one needs to be replaced, call 877.427.3920 to schedule a service call.

Sabbath Mode

Enable Sabbath mode on the electronic control.

- Swipe the display right or left to access the main options screen.
- Press and hold the Sabbath mode icon for two seconds. When Sabbath mode is enabled, the home screen will display the icon.
- Press and hold the Sabbath icon on the home screen for two seconds to disable Sabbath mode.

Vacation

For extended vacations, do the following:

- Turn the refrigerator off using the power switch, located behind the top grille on the right.
- Turn off the water supply to the refrigerator.
- Empty the refrigerator, including the ice pan.
- Block the doors open to let air circulate and keep the interior dry.

Care and Cleaning

Cleaning

Before cleaning, turn the refrigerator off using the power switch, located behind the top grille. When finished cleaning, turn the refrigerator on.

Stainless Steel Doors and Interior

Use a non-abrasive stainless steel cleaner and a soft cloth. Always follow the grain of the stainless steel.

Painted Doors and Other Surfaces

Use a mild solution of soap and water and a soft cloth.

Condenser

⚠ CAUTION

Electrical Shock Hazard

Turn power off before cleaning condenser. Vacuum in the direction of the fins to avoid damaging condenser fins. Failure to follow these instructions can result in death, electrical shock, or fire.

⚠ MISE EN GARDE

Risque de choc électrique

Mettre le réfrigérateur hors tension avant de nettoyer le condenseur. Aspirer dans le sens des ailettes du condenseur pour éviter de les endommager. Le non-respect de ces instructions peut entraîner la mort, un choc électrique ou un incendie.

Clean the condenser every three to six months to ensure proper operation.

1. Lift up the top grille and turn the power off. The condenser is on the left.

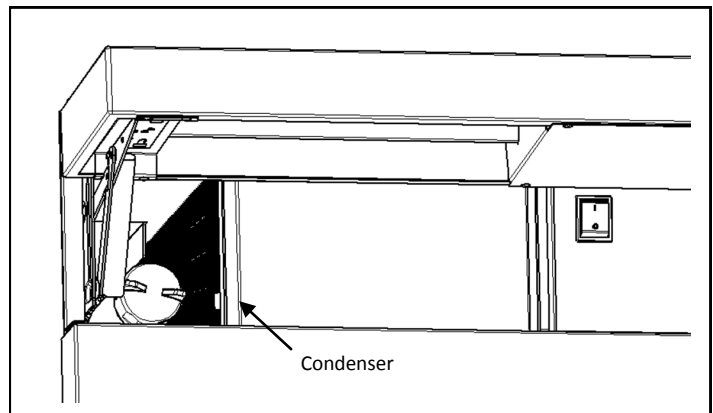

2. Use a soft bristle brush and vacuum to remove dust and lint from the condenser. Vacuum in the direction of the fins to avoid damaging the condenser.
3. Turn the power on and lower the top grille.

Troubleshooting

The refrigerator makes unusual noises.

- The following noises are normal:
 - * Buzzing when the water valve opens to fill the ice maker
 - * Clattering when ice is dropped from the ice maker into the stainless steel pan
 - * Whirring when the fans are operating

The refrigerator will not operate.

- Confirm the power switch, located behind the top grille, is on.
- Confirm the circuit breaker and electrical power to the refrigerator are on.

The lights are not working.

- Verify the doors are closed. If doors were left open, the lights turn off after ten minutes to eliminate excess heat.

The refrigerator seems to run too much or the temperature is too warm.

- If a large load of food was added, doors were opened frequently, or doors were left open, the compressors and fans will run to maintain the set temperature.
- Verify the doors are closed or closing properly.
- Confirm there are no tears in the gaskets. If there are tears in the gaskets, call service at 877.427.3290.
- Confirm whether the room temperature is hotter than normal. Increased ambient temperatures may cause compressors to run longer.

There is condensation, frost, or ice on the inside of the refrigerator and/or freezer.

- Verify the doors are closed.
- Confirm there are no tears in the gaskets. If there are tears in the gaskets, call service at 877.427.3290.

The ice maker is not making ice.

- Confirm the ice maker setting on the electronic control is on and the bale arm on the ice maker is in the on (lowest) position.
- Confirm the ice maker has been on for at least 24 hours.
- Verify the freezer temperature is 0°F.
- Confirm water to the refrigerator is turned on.
- Verify the water filter has been replaced and installed correctly.

The ice is sticking together in the ice bin.

- It is normal for ice to stick together if it has not been used frequently. Empty the ice bin.

The ice has a bad taste and/or odor.

- Throw away ice if it has not been used in a long time.
- Clean the freezer compartment.
- Verify the water filter has been replaced and installed correctly.

The refrigerator has an odor.

- Confirm food is adequately covered as uncovered food could create odors.
- Clean the refrigerator thoroughly.

If assistance is still required, please call service at 877.427.3290.

Limited Warranty

Who Is Providing The Warranty? Prizer-Painter Stove Works, Inc. ("Prizer-Painter") warrants the parts of your BlueStar® refrigeration appliance ("Product") as described below.

Who Does This Warranty Cover? This Warranty covers the owner of the residence in which the Product is installed, and his or her spouse ("Owner").

What Products Does this Warranty Cover? This Warranty applies only to BlueStar® refrigeration appliances purchased in the continental U.S. and Canada and installed in residential properties only for normal residential use. The Product must be installed by a trained technician for the Warranty to apply. Damages resulting from self-installations and/or installations or product mountings inconsistent with the Product specifications void this Warranty. This Warranty is also void if the original factory installed serial number is altered or removed from the Product.

What Products Does this Warranty Not Cover? This Warranty does not cover Products installed or used in any commercial or other non-residential property such as, but not limited to, day care facilities, hotels, motels, inns, and nursing homes. This Warranty does not cover Products installed outside the U.S. or Canada.

What Does this Warranty Provide? Subject to the specific conditions and limitations below, this Warranty covers parts and labor necessary to repair or replace any part of the Product that contains defects in materials and workmanship that appear under normal use and maintenance of refrigeration appliances in residential properties.

Two Year Warranty. For two (2) years from the date of installation, this Warranty covers all parts and labor necessary to repair or replace any part on the Product that proves defective.

Five Year Warranty--Sealed System. For five (5) years from the date of installation, this Warranty covers all parts and labor on the compressor, condenser, evaporator, drier and all connecting tubing.

Thirteen Year Limited Warranty –Sealed System. For thirteen (13) years from the date of installation, the compressor, condenser, evaporator, drier, and all connecting tubing are covered by a limited parts only warranty.

Cosmetic Component Warranty. This Warranty covers visible chips, scratches and dents for sixty (60) days from the installation date of the Product by the original purchaser. Cosmetic components include stainless steel and painted doors, handles, and surfaces.

Floor Models Not Used For Demonstration. There is no cosmetic warranty of any kind for floor models. All other applicable Warranties apply from the date of purchase.

Floor Models Used For Demonstration. Floor models used for demonstration are covered by a ninety (90) day limited parts warranty only, from the date of installation. There is no service or cosmetic warranty of any kind for floor models.

Exceptions. The replacement of a part or Product under this Warranty does not extend the Warranty period. None of these Warranty periods continues if the Product is removed from the location where it was originally installed. Warranty service in areas beyond a 30 mile radius from an authorized BlueStar® retailer or service provider may require certain costs to the consumer.

What Problems Does this Warranty Not Cover? This Warranty does not cover, and specifically excludes:

- Damage caused by shipping.
- Normal adjustments after installation and setup.
- Normal wear, care, and maintenance of the Product as described in the Use and Care Guide.
- Replacement water filters.
- Damage or repairs caused by alterations or modifications, abuse, misuse, neglect, or improper installation, mounting, handling, operation, maintenance or storage.
- Accidental or intentional damage.
- Damage or repairs caused by unauthorized service or repairs, including unauthorized adjustments or calibrations performed on the Product.
- Damage or repairs as a result of natural disasters, fires, floods, earthquakes, winds, lightning, corrosive atmosphere, loss of electrical power to the Product for any reason, or other conditions beyond Prizer-Painter's control.
- Damage or repairs caused by alteration for outdoor use.
- Damage or repairs caused by the use of harsh chemicals or cleaning products improperly applied.

How Can An Owner Obtain Warranty Service? All Warranty claims must be submitted to Prizer Painter Customer Service by calling 877.427.3290 prior to the expiration of the applicable Warranty periods set forth above.

How Do I Register for the Warranty? TO REGISTER, please visit www.bluestarcooking.com/support/product-registration, or call Customer Service (877.427.3290) for assistance.

For further information about this warranty,
contact Prizer Painter Customer Service at 877.427.3290.

Limited Warranty

California and Quebec Residents. Failure by California and Quebec residents to register does not diminish warranty rights.

LIMITATIONS ON LIABILITY. This Warranty is in lieu of all other express warranties. **ALL IMPLIED WARRANTIES, INCLUDING BUT NOT LIMITED TO WARRANTIES OF MERCHANTABILITY AND FITNESS FOR PARTICULAR PURPOSE ARE LIMITED TO THE DURATION OF THIS WARRANTY.** Some states and provinces do not allow limitations on implied warranties, so the above limitations may not apply to you.

THE OWNER AND PRIZER-PAINTER AGREE THAT THE REMEDIES SET OUT HEREIN ARE THE OWNER'S EXCLUSIVE REMEDIES FOR BREACH OF ALL WARRANTIES, EXPRESS OR IMPLIED.

WHETHER ANY CLAIM IS BASED ON NEGLIGENCE OR OTHER TORT, BREACH OF WARRANTY OR BREACH OF CONTRACT, OR ANY OTHER TORT THEORY, PRIZER-PAINTER SHALL IN NO EVENT BE LIABLE FOR INCIDENTAL, CONSEQUENTIAL OR SPECIAL DAMAGES, INCLUDING BUT NOT LIMITED TO EXTRA UTILITY EXPENSES, SHIPPING COSTS RELATED TO REPAIR OR REPLACEMENT OF ANY PRODUCT OR DAMAGES TO PROPERTY, RESULTING FROM BREACH OF THIS WARRANTY OR ANY IMPLIED WARRANTY. Some states and provinces do not allow the exclusion or limitation of incidental or consequential damages, so this provision may not apply to you.

This Limited Warranty gives you specific legal rights, and you may also have other rights that may vary from state to state or province to province.

Where Can Any Legal Remedies Be Pursued? Please read carefully the Arbitration Clause and its Provisions, which affect your legal rights. The Arbitration Clause is also available on Prizer-Painter's website.

ARBITRATION CLAUSE. IMPORTANT. PLEASE REVIEW THIS ARBITRATION CLAUSE. IT AFFECTS YOUR LEGAL RIGHTS.

1. Parties: This arbitration clause affects your rights against Prizer-Painter Stove Works, Inc. and any of its affiliates or employees or agents, successors, or assigns, all of whom together are referred to as "we" or "us" for ease of reference.

2. ARBITRATION REQUIREMENT: EXCEPT AS STATED BELOW, ANY DISPUTE BETWEEN YOU AND ANY OF US SHALL BE DECIDED BY NEUTRAL, BINDING ARBITRATION RATHER THAN IN COURT OR BY JURY TRIAL. "Dispute" will be given the broadest possible meaning allowable by law. It includes any dispute, claim, or controversy arising from or relating to your purchase of a Prizer-Painter Product, any warranty upon the unit, or the unit's condition. It also includes determination of the scope or applicability of this Arbitration Clause. The arbitration requirement applies to claims in contract and tort, pursuant to statute, or otherwise.

3. CLASS-ARBITRATION WAIVER: ARBITRATION IS HANDLED ON AN INDIVIDUAL BASIS. IF A DISPUTE IS ARBITRATED, YOU EXPRESSLY WAIVE ANY RIGHT TO PARTICIPATE AS A CLASS REPRESENTATIVE OR CLASS MEMBER ON ANY CLASS CLAIM YOU MAY HAVE AGAINST US, OR AS A PRIVATE ATTORNEY GENERAL OR IN ANY OTHER REPRESENTATIVE CAPACITY. YOU ALSO WAIVE ANY RIGHT TO CLASS ARBITRATION OR ANY CONSOLIDATION OF INDIVIDUAL ARBITRATIONS.

4. Discovery and Other Rights: Discovery and rights to appeal in arbitration are generally more limited than in a lawsuit. This applies to both you and us. Other rights that you or we would have in court may not be available in arbitration. Please read this Arbitration Clause and consult the rules of the arbitration organizations listed below for more information.

5. SMALL CLAIMS COURT OPTION: YOU MAY CHOOSE TO LITIGATE ANY DISPUTE BETWEEN YOU AND ANY OF US IN SMALL CLAIMS COURT, RATHER THAN IN ARBITRATION, IF THE DISPUTE MEETS ALL REQUIREMENTS TO BE HEARD IN SMALL CLAIMS COURT.

6. OPTING OUT OF THIS ARBITRATION CLAUSE: YOU MAY OPT OUT OF THIS ARBITRATION CLAUSE WITHIN 60 DAYS OF PURCHASE, IF YOU INFORM PRIZER-PAINTER IN WRITING, VIA REGISTERED MAIL (PRIZER-PAINTER, 318 June Ave., Blandon, PA 19510) THAT YOU ARE OPTING OUT. There is no other procedure to opt out. Opting out of this Arbitration Clause will not affect your other rights under this warranty.

7. Governing Law: The procedures and effect of the arbitration clause will be governed by the Federal Arbitration Act (9 U.S.C. § 1 *et seq.*) rather than by state law concerning arbitration. The law governing your warranty rights or other claims will be the law of the state in which you purchased your Product. Any court having jurisdiction may enter judgment on the arbitration award.

8. Rules of the Arbitration: If the amount in controversy is less than \$50,000, the arbitration will be decided by a single arbitrator. If the amount in controversy is greater than or equal to \$50,000, the arbitration will be decided by a panel of three arbitrators. The arbitrator(s) will be chosen pursuant to the rules of the organization that administers the arbitration. You may choose either of the following arbitration organizations, and its applicable rules: the American Arbitration Association, 1633 Broadway, 10th Floor, New York, NY 10019 (www.adr.org); JAMS, 1920 Main Street, Ste. 300, Irvine, CA 92614 (www.jamsadr.com); or other organization that you may choose subject to our approval. These organizations' rules can be obtained by contacting or visiting the organization's website. If the arbitration organization's rules conflict with this Arbitration Clause, the provisions of this Arbitration Clause control. The award of the arbitrator(s) shall be final and binding on all parties.

For further information about this warranty,
contact Prizer Painter Customer Service at 877.427.3290.

Limited Warranty

9. Location of the Arbitration Hearing: Unless applicable law provides otherwise, the arbitration hearing will be conducted in the federal district in which you reside.

10. Costs of the Arbitration: Each party is responsible for its own attorney, expert and other fees, unless awarded by the arbitrator(s) under applicable law. Prizer-Painter will pay your share of the fees charged by the arbitration organization and arbitrator(s) beyond the first \$200. Where permissible by law, you may be required to reimburse Prizer-Painter for the fees of the arbitration organization and arbitrator(s) in whole or in part by decision of the arbitrator(s) at the discretion of the arbitrator(s).

11. Survival and Enforceability of this Arbitration Clause: This Arbitration Clause shall survive the expiration or termination, or any transfer, of the warranty on your unit. If any part of this Arbitration Clause, except waivers of class-action rights, is found to be unenforceable for any reason, the remainder shall remain enforceable. If, in a case in which class-action allegations have been, a waiver of class-action rights is found to be unenforceable with respect to all or some parts of a dispute, the remainder of this Arbitration Clause shall be unenforceable as those parts. Instead, those parts will be severed and proceed in court, with the remaining parts proceeding in arbitration.

Name of Owner: _____

Address of Installation: _____

City/State-Province/Zip-Postal Code: _____

Phone #: _____

Model #: _____ Serial #: _____

Installation Date: _____

For further information about this warranty,
contact Prizer Painter Customer Service at 877.427.3290.



Tested and Certified in System Model BS-AP2-200G
against NSF/ANSI Standards 42 and 53 for the
reduction of the claims specified on the
Performance Data Sheet.