

INSTALLATION MANUAL



BLUESTAR[®]

Double Electric Wall Oven

799258

BLUESTAR[®] INSTALLATION INSTRUCTIONS FOR THE RESIDENTIAL ALL ELECTRIC WALL OVEN FOR THE HOME

MODELS DEWO

THIS APPLIANCE WAS DESIGNED FOR EASE OF INSTALLATION AND OPERATION. HOWEVER, WE RECOMMEND THAT YOU READ ALL SECTIONS OF THIS MANUAL BEFORE YOU BEGIN INSTALLATION. INSTALLATION MUST BE PERFORMED BY AN APPROVED ELECTRICIAN OR CERTIFIED INSTALLATION TECHNICIAN CAPABLE OF PERFORMING THE MANUFACTURER'S INSTALLATION CHECKLIST. THE INSTALLATION CHECKLIST IS INCLUDED AT THE REAR OF THIS BOOKLET.

DO NOT REMOVE PERMANENTLY AFFIXED LABELS, WARNINGS OR DATA PLATES FROM YOUR APPLIANCE. THIS MAY VOID THE MANUFACTURER'S WARRANTY AND/OR HINDER EFFECTIVE SERVICING AND MAINTENANCE.

THESE INSTRUCTIONS ARE TO REMAIN WITH THE APPLIANCE AND THE CONSUMER IS TO RETAIN THEM FOR FUTURE REFERENCE.

WARNING! If the information in this manual is not followed exactly, a fire or explosion and/or shock may result causing property damage, personal injury or death.
FOLLOW ALL NATIONAL ELECTRICAL CODES, STATE AND OR LOCAL CODES THAT APPLY TO ELECTRICAL APPLIANCES

Do not store or use gasoline or other flammable vapors and liquids in the vicinity of this or any other appliance.

WHAT TO DO IF YOU SMELL WIRE BURNING

Do not try to turn on the appliance
Do not touch or activate any electrical switch
Please disconnect the unit by turning off the circuit breaker or fuse
If smell continues or increased please contact the fire department

Installation and service must be performed by a qualified installer, electrician or service agency

DANGER! ELECTRICAL SHOCK HAZARD EXISTS IF INSTALLATION AND SERVICE ARE PERFORMED BY UNQUALIFIED PERSONNEL

To avoid risk of electrical shock, personal injury; verify the unit has been properly grounded in accordance with local codes, with National Electric Code (NEC), ANSI/NFPA 70 or updated edition

All specifications are subject to change without prior notification.



NOTE: WARRANTY SERVICE MUST BE PERFORMED BY AN AUTHORIZED SERVICE AGENT. YOU MAY REQUEST WARRANTY SERVICE BY CALLING 800-449-8691. YOU MAY ALSO REQUEST SERVICE AT WWW.BLUESTARCOOKING.COM

Please take a few moments now to fill in the information below for your future reference. In the event you require parts or service, this information will be needed to ensure you receive the highest quality service we can provide.

DATE OF PURCHASE

DEALER'S NAME

DEALER'S ADDRESS

DATE OF INSTALLATION

INSTALLER'S NAME

INSTALLER'S ADDRESS

MODEL NUMBER

SERIAL NUMBER

SAFETY INSTRUCTIONS

To avoid personal injury or property damage, please read and follow these important safety precautions.

1. Before any maintenance or repairs are performed, disconnect the appliance from the electric supply.
2. Your appliance should be installed by a qualified electrician or installation technician. Have the technician show you the exact location of the circuit breaker and/or fuse on the incoming electrical panel so you know how to turn off the electricity to the unit if necessary.
3. In the event of a power failure, the unit will shut off, do not attempt to operate the appliance.
4. Do not attempt to repair or replace any part of this appliance unless specifically instructed to do so by this manual. In-warranty service must be performed by an authorized service agency.
5. Do not store flammable materials on or near the appliance. Keep the appliance area clean and free of combustible materials, gasoline and other flammable vapors and liquids. A check before each use to determine that no hazardous materials are in the area is recommended.
6. The electronic control has a lock feature designed to be child-safe, however, not a guarantee of safe operation. Children should not be left alone or unattended in the kitchen while the appliance is in use.
7. This appliance is designed for zero clearance installation although the front of the unit should not be obstructed.
8. The ventilation and flue ways of this appliance must remain unobstructed at all times.
9. Do not store items of interest to children above the appliance. Children, as well as adults, should never be allowed to sit, stand, or climb on any part of the appliance. Serious injury may occur.
10. Never leave the appliance unattended during use.
11. Do not use water on grease fires. Never pick up a flaming pan. It is recommended you purchase a multi-purpose dry chemical or foam-type fire extinguisher for your home. Store it in close proximity to your appliance.
12. For your safety, never use your appliance or any other cooking appliance as a space heater to warm or heat the room.
13. All local and national codes and ordinances must be observed. Installation must conform with local codes.
14. In Canada: Installation must be in accordance with the current local codes.
15. Use only dry potholders. Moist or damp potholders on hot surfaces may result in steam burns. Do not allow potholders to touch hot areas. Do not use a towel or other bulky material as a potholder.
16. To reduce the risk of burns, ignition of flammable materials, and spillage, care should be taken when loading and unloading the oven.
17. To avoid personal risk or injury, this unit requires two or more personnel when lifting, handling, or moving this appliance. Do not use the handle or oven door to lift the oven. Remove door before installation to ensure no damage is resulted in lifting of the oven.
18. Wear proper apparel, loose fitting or hanging garments should never be worn while using this appliance.
19. Placement of Oven Racks- Always place oven racks in desired position while oven is cool. If racks must be moved while hot, do not let pot holder contact heating element in oven.
20. To prevent fire and smoke damage ensure all packing materials are removed from the appliance.
21. Keep area around appliance free and clear of all combustible materials, gasoline, and other flammable vapors.

22. Many aerosol spray cans can be explosive when exposed to heat—Do not store near appliance.
23. Many plastics are vulnerable to heat—Do not store near appliance.
24. The misuse of the oven door; sitting, stepping or leaning on, can result in hazards or injuries and damage to the appliance or user.
25. Do not drape towels or materials on oven doors. These articles may ignite.
26. Always follow food manufacturers instructions for food handling and preparation. Always maintain sanitary conditions.
27. OVEN WILL GET HOT! Never touch the inside of the oven cavity or oven element when in operation. As with any cooking appliance, surfaces will get hot. Personal injury or harm may occur.

SITE PREPARATION

- This appliance has been designed to be installed directly inside cabinets.
- Cabinet should be structurally capable of supporting the weight of the oven(s).
- Each appliance shall be located with respect to building construction and other equipment to permit access to the appliance. Such access and clearance is necessary for cleaning and servicing.
- Due to its size and weight, a rolling lift jack, air sled or pallet jack should be used to move the appliance into position.
- Do not push against the edges or sides of any appliance in an attempt to slide it into position. Although all sharp metal parts are de-burred during the manufacturing process, serious injury could occur if the appliance were to move suddenly while being positioned. We recommend you use gloves during the installation process.
- Do not use the kick panel or oven door handle to push or pull the appliance into position.
- For optimum performance the appliance should be leveled during installation. Ensure the cabinet mounting surface is level using a carpenter-type level. The level should be placed on the surface three ways: side to side, front to back, and diagonally.
- The appliance is equipped with a 5" handy box for electrical connections. All local and other codes regarding electrical connections must be observed.
- All electrical wiring should be free and clear. Wires or cables should not be pinched or otherwise obstructed.

CLEARANCES AND DIMENSIONS

CLEARANCES AND DIMENSIONS

BLUESTAR DOUBLE ELECTRIC WALL OVEN SWING/DROP DOOR 30"

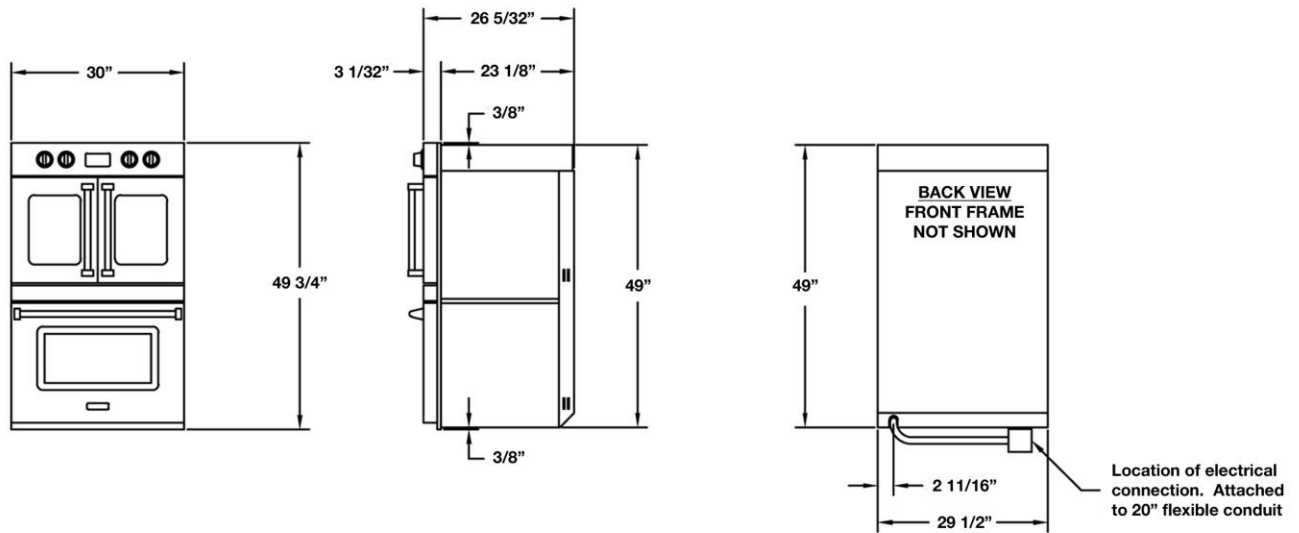

SPECIFICATIONS:

TOP OVEN:

- 30" OVEN 26.25"W x 20"D x 15"H
- OVEN BROILER ELEMENT RATING 5000 WATTS
- OVEN BAKE ELEMENT RATING 2500 WATTS
- OVEN HEAT ASSIST ELEMENT 1800 WATTS

BOTTOM OVEN:

- 30" OVEN 26.25"W x 20"D x 15"H
- OVEN BROILER ELEMENT RATING 2500 WATTS
- OVEN BAKE ELEMENT RATING 2500 WATTS
- OVEN HEAT ASSIST ELEMENT 1800 WATTS

ELECTRICAL REQ. 240V, 60Hz, 40 AMPS, 1 PH
(UNIT MUST BE ON A NON-GFI, DEDICATED OUTLET)

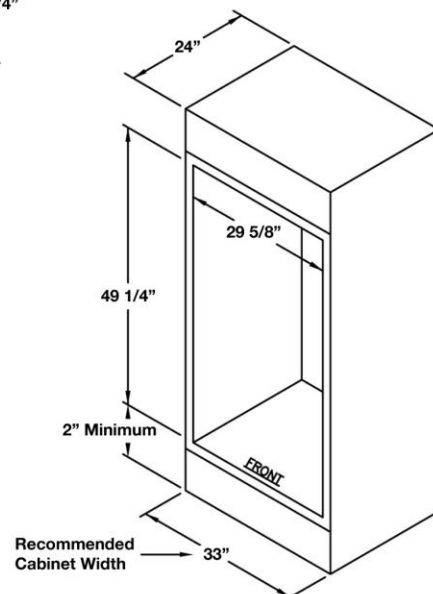
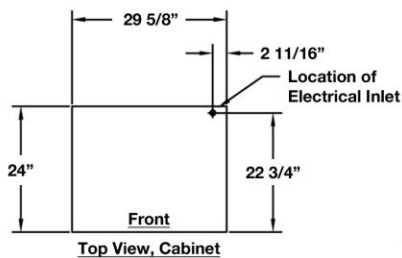

CLEARANCES

CLEARANCES AND DIMENSIONS
BLUESTAR DOUBLE ELECTRIC WALL OVEN 2 DROP DOORS 30"

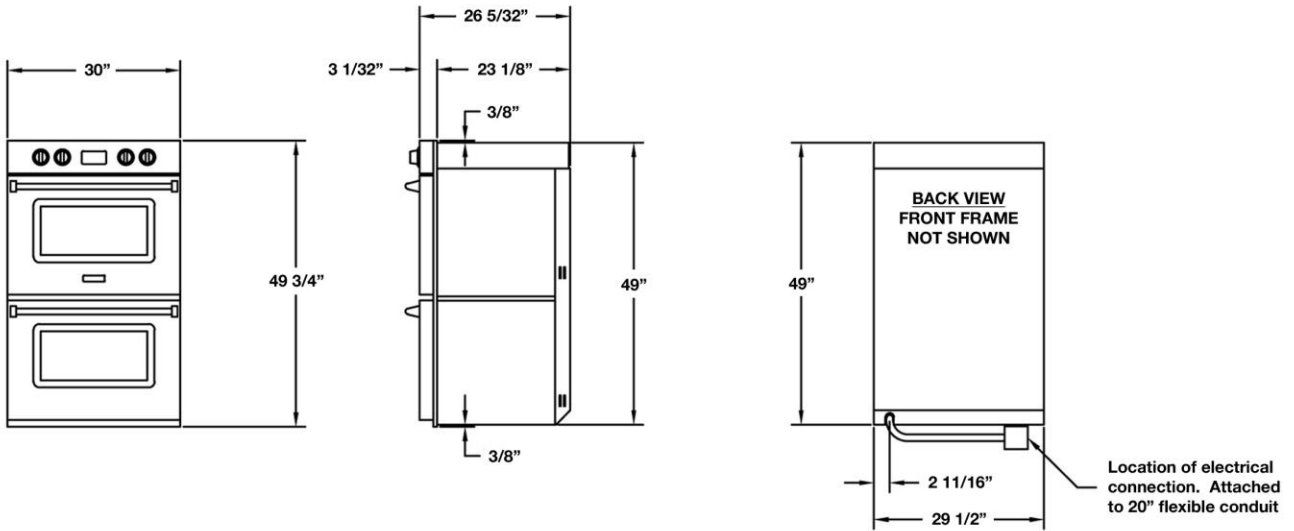

SPECIFICATIONS:

TOP OVEN:

- 30" OVEN 26.25"W x 20"D x 15"H
- OVEN BROILER ELEMENT RATING 5000 WATTS
- OVEN BAKE ELEMENT RATING 2500 WATTS
- OVEN HEAT ASSIST ELEMENT 1800 WATTS

BOTTOM OVEN:

- 30" OVEN 26.25"W x 20"D x 15"H
- OVEN BROILER ELEMENT RATING 2500 WATTS
- OVEN BAKE ELEMENT RATING 2500 WATTS
- OVEN HEAT ASSIST ELEMENT 1800 WATTS

ELECTRICAL REQ. 240V, 60Hz, 40 AMPS, 1 PH
 (UNIT MUST BE ON A NON-GFI, DEDICATED OUTLET)

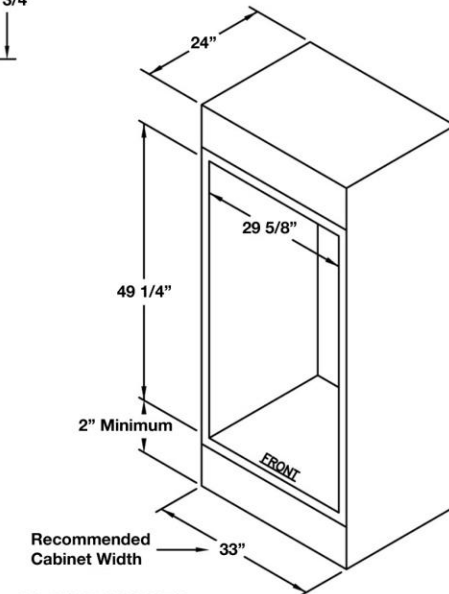
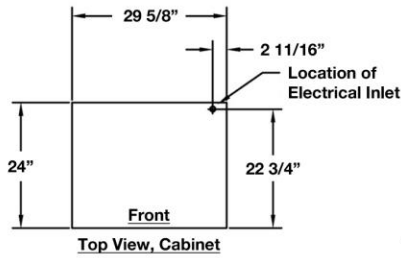

CLEARANCES

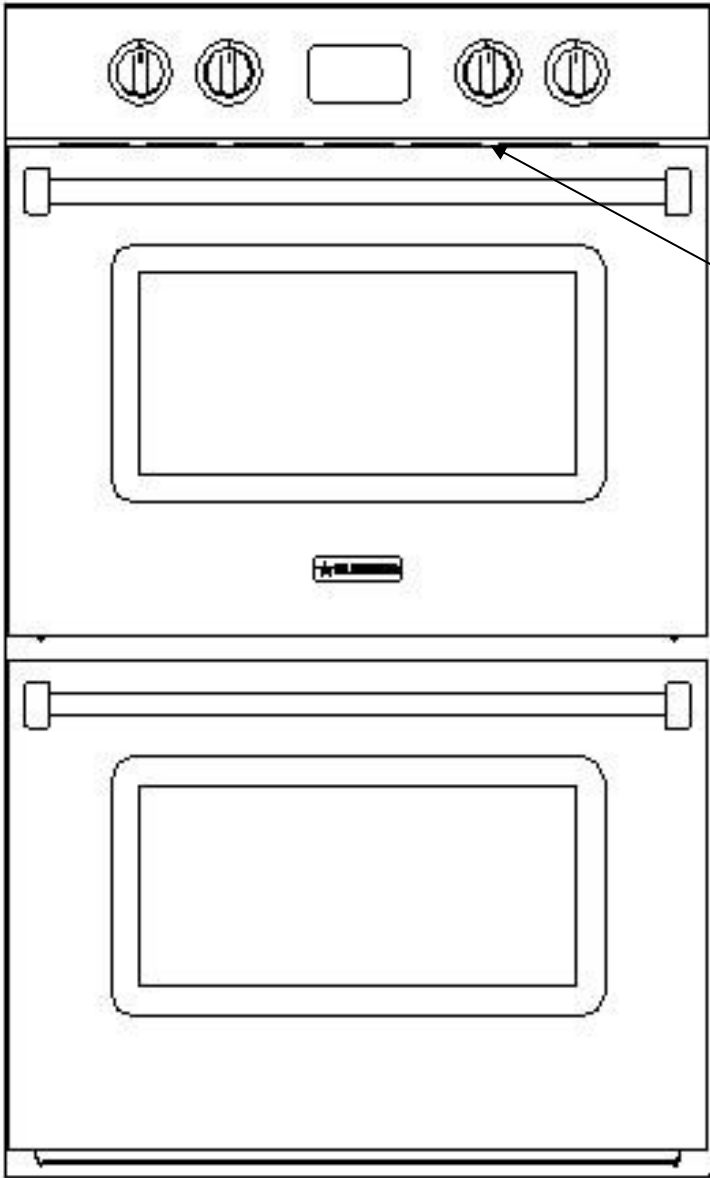

SERIAL NUMBER LOCATION

INSTALLATION

UNPACKING

1. Check the package for damage. If any damage is visible you should mark the Bill of Lading you sign that there may be concealed damage. If there is visible damage, contact the dealer you purchased your appliance from.
2. Ensure the container is upright. If the container is not upright major damage can occur to your appliance. If damage is discovered, do not refuse delivery. Contact the dealer and file appropriate freight claims. Save all packaging material. Do not contact the manufacturer. Your appliance was shipped from the dealer you purchased it from. Shipping damage claims are to be resolved between the customer, shipping carrier and dealer. The manufacturer may assist in resolving any such claims, but such assistance does not relieve you of your responsibility.
3. Move the container as close to its installation location as possible. This will reduce moving and handling your appliance once it is out of its shipping container.
4. Cut the straps holding the carton to the palette. Lift the box directly up and off the appliance. Do not use a hammer. Do not cut the carton with a razor, utility or box cutting knife.
5. Thoroughly inspect your appliance for damage. If damage is discovered, do not refuse delivery. Contact the dealer and file appropriate freight claims. Save all packaging material. Do not contact the manufacturer. Your appliance was shipped from the dealer you purchased it from. Shipping damage claims are to be resolved between the customer, shipping carrier and dealer. The manufacturer may assist in resolving any such claims, but such assistance does not relieve you of your responsibility.
6. Remove and unpack any accessories shipped with your appliance. Make sure no hardware or accessories are left to be disposed of unintentionally.
7. Complete wiring connections in 5" handy box.
8. Insert unit into cabinet until front frame of unit is flush against cabinet.
9. Remove control panel of unit and insert screw through control box of unit into side of cabinet.
10. Test functionality of oven following the performance check list.

ELECTRICAL CONNECTIONS

1. The installation of this appliance must conform with all applicable local codes. In the absence of local codes, the installation must conform to the latest level of the National Electric Code, and ANSI/NFPA 70.
2. This appliance is configured to work with 208, 220, 240 volt single phase 60Hz power.
3. Unit must be grounded.
4. The electrical connection exits the appliance at the lower rear toward the right (viewed from front) side. Where a 5" handy box is supplied for field connections.
5. If the electrical supply is not turned on or is interrupted, the appliance will not operate.
6. The applicable wiring diagram for this appliance is affixed to the appliance.
7. The circuit where you plug your appliance must be grounded and polarized.
8. We recommend the circuit for your appliance be a non-GCFI dedicated line.
9. It is recommended that your circuit never include a microwave oven.
10. The electrical connection provided is 4 wires...neutral, ground, L1, L2.
11. If the current power is a 3 wire system it will be required to place a jumper wire from the ground to neutral location on the terminal block located inside the control compartment of the unit.

SERVICE

If the appliance requires service, to gain access to the control compartment panel please follow the below steps:

- Remove screws attaching control panel.
- Let control panel slide down from mounting pins, be careful with wiring connected to control panel.
- Pull control panel forward to remove.

REPLACEMENT PARTS

- Replacement Parts can be acquired by calling Customer Service at 1-800-449-8691

WARNING

This appliance is intended to be grounded. Do NOT cut, remove or disregard the grounding wire in this unit. If the appliance is not grounded severe shock hazards can exist.

WIRING DIAGRAM

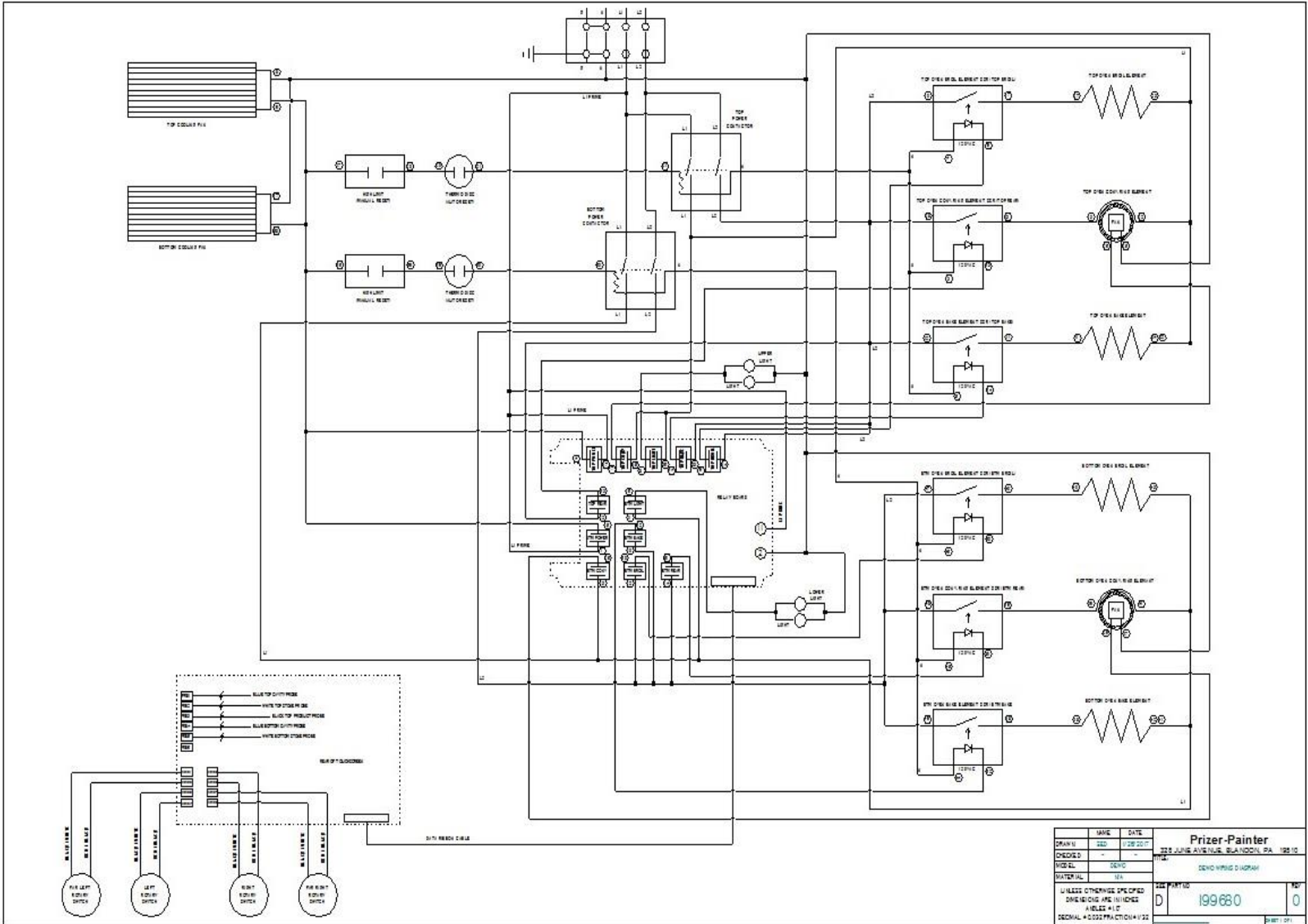

| | | |
|---|--|---------------------------|
| Prizer-Painter 225 JUNE AVENUE, BLANDON, PA 18610 | | |
| DRAWN BY: [] CHECKED: [] DESIGNED: [] MATERIAL: [] | DATE: 12/22/77 TITLE: DEVO WIRING DIAGRAM | PART NO: 199660 QTY: 0 |
| UNLESS OTHERWISE SPECIFIED DIMENSIONS ARE IN INCHES FRACTIONS ARE 1/16" | | |
| DECIMALS TO 3 DECIMAL PLACES | | |

PERFORMANCE CHECKLIST

This checklist has been developed to assure proper installation of your appliance.

To validate your warranty you must mail, email or submit this form online within 90 days of installation, with a copy of your receipt to: Warranty Department, Prizer-Painter Stove Works Inc., 318 June Avenue Blandon, PA 19510 or submit online at bluestarcooking.com.

| Customer Information (Please Print) | Product Information (Please Print) |
|-------------------------------------|------------------------------------|
| Name: _____ | Model No: _____ |
| Address: _____ | Serial No: _____ |
| City: _____ | Purchase Date: _____ |
| State, Zip Code: _____ | Installation Date: _____ |
| e-mail: _____ | Installer's Name: _____ |
| Telephone: _____ | Company: _____ |
| Dealer: _____ | Telephone: _____ |

CHECK ALL THAT APPLY

Appearance and Aesthetics

- Exterior
- Oven interior

Installation

- Proximity to cabinets
- Level
- Ventilation system
- Read User Manual
- Review safety instructions

Controls

- Quick control knobs
- Thermostats
- Convection oven fan & operation
- Oven light operation
- Display screen

Electrical Connection

- Correct voltage
- Grounded outlet
- No GFCI

Heating Elements Function

- Oven Burner
- Infrared Broiler

Oven Door

- Alignment
- Door seal
- Hinges