

Introducing the new BlueStar<sup>®</sup> Double Electric Wall Oven – the power, performance and quality of a BlueStar are now available in electric. Professional-level performance features make this oven the perfect addition to any chef's kitchen.

### PRODUCT FEATURES

- Extra-large oven with True European Convection
- Accommodates a full-size 18" x 26" baking sheet
- Eco-friendly Continu Clean feature continuously cleans the oven cavity

#### TOP OVEN FEATURES:

- Powerful 2,500 watt bake element plus 1,800 watt heat assist for faster preheat
- Commercial-grade intense 5,000 watt infrared broiler for restaurant-quality results
- Built-in artisan baking stone with precise temperature control
- Intuitive touch screen control with 12 cooking modes including Bake, StoneBake & Roast
- Precision temperature probe

#### BOTTOM OVEN FEATURES:

- Powerful 2,500 watt bake element plus 1,800 watt heat assist for faster preheat
- 2,500 watt infrared broiler element
- Intuitive touch screen control with 10 cooking modes including Bake, Proof & Sabbath

### SPECIFICATIONS

Unit Dimensions: 30"W x 26 5/32"D x 49 3/4"H

Oven Interior: 26.25"W x 20"D x 15"H

Oven Bake Element: 2,500 watts (Both units)

Oven Broiler Element: 5,000 watts (Top oven)

Oven Broiler Element: 2,500 watts (Bottom Oven)

Oven Heat Assist Element: 1,800 watts (Both units)

Electrical Requirements: 240V, 60Hz, 50 AMPs, 1 PH  
(Unit must be on a Non-GFI, dedicated outlet)



### MODEL CONFIGURATION

Double Electric Wall Oven BWOEWO30ECSDDDV2  
with French & Drop Down Doors

### ADDITIONAL CUSTOMIZATION OPTIONS

- 750+ color options
- Knob colors
- Trim options

*All specifications subject to change without notice.  
Visit [www.bluestarcooking.com](http://www.bluestarcooking.com) prior to site  
preparation or installation.*

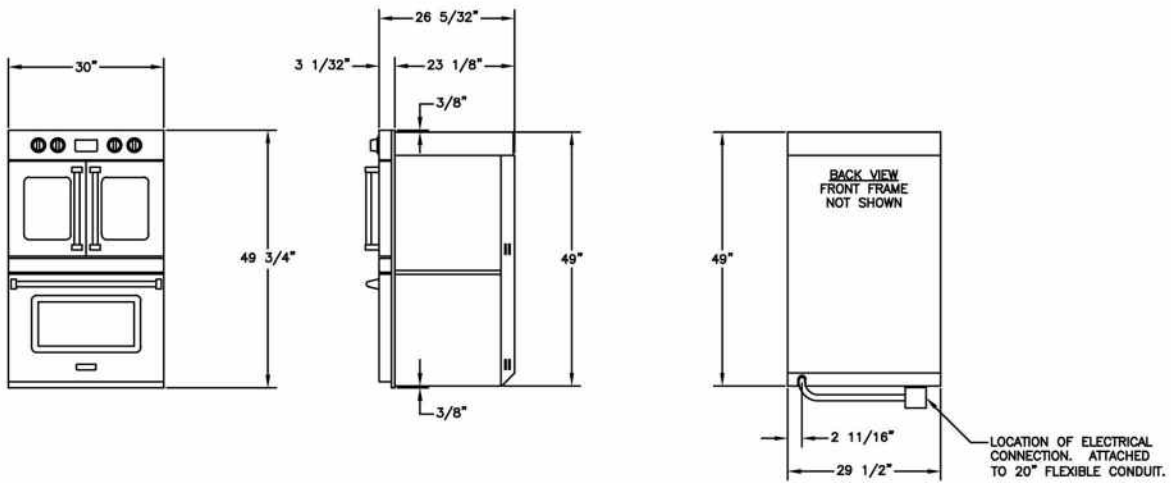
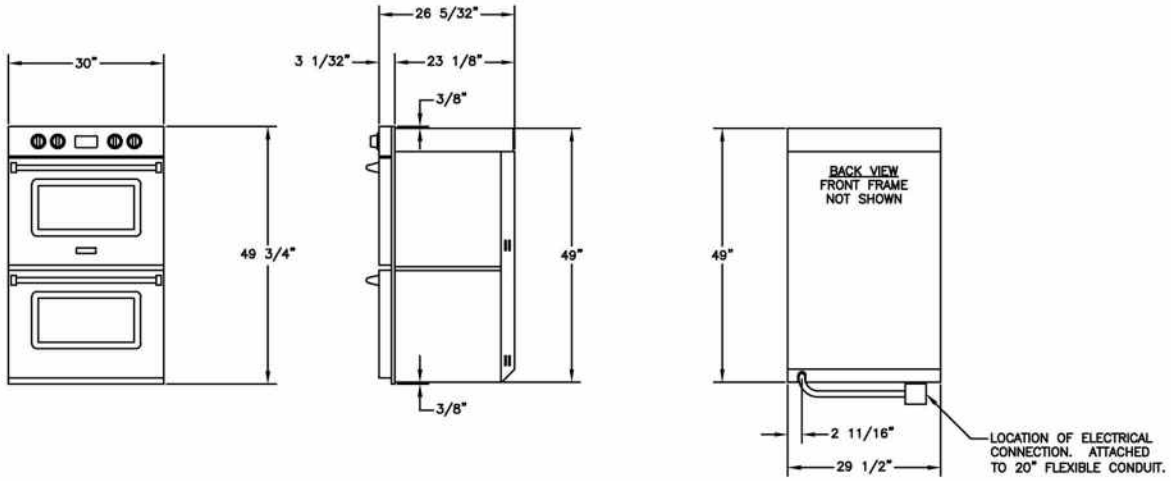

**SPECIFICATIONS:**

**TOP OVEN:**

- 30" OVEN: ----- 26.25"W x 20"D x 15"H
- OVEN BROILER ELEMENT RATING --- 5000 WATTS
- OVEN BAKE ELEMENT RATING --- 2500 WATTS
- OVEN HEAT ASSIST ELEMENT --- 1800 WATTS

**BOTTOM OVEN:**

- 30" OVEN: ----- 26.25"W x 20"D x 15"H
- OVEN BROILER ELEMENT RATING --- 2500 WATTS
- OVEN BAKE ELEMENT RATING --- 2500 WATTS
- OVEN HEAT ASSIST ELEMENT --- 1800 WATTS

• ELECTRICAL REQUIREMENTS --- 240V, 60Hz, 50 AMPS, 1 PH  
(UNIT MUST BE ON A NON-GFI, DEDICATED OUTLET)

