

BlueStar® has combined professional level features and handcrafted quality into the Culinary Series - Sealed Burner line. Cook like a pro with professional level power and versatility with 21,000 BTUs\* of searing power plus a precise simmer burner. The new 48" Culinary Series - Sealed Burner features an extra-large convection oven that will accommodate a commercial size baking sheet plus a companion oven that accommodates a half size sheet pan. Create a custom design with your choice of 1,000+ colors, 10 metal trims and colored knobs.



### PRODUCT FEATURES

- 8 sealed burners for maximum cooking area
- Powerful 21,000\* BTU burners
- Precise 5,000 BTU simmer burner
- 2 over-sized ovens
- 30" convection oven fits commercial size sheet pans
- 1850° commercial-grade infrared broiler
- Available in 1,000 colors and finishes plus 10 metals trims
- Handcrafted in Pennsylvania since 1880

### SPECIFICATIONS

Range Dimensions: 47.875"W x 24"D x 36.75"H  
 Large Oven Interior: 29"W x 20"D x 15"H  
 Small Oven Interior: 12"W x 20"D x 15"H  
 Top Burner Rating: NAT 21,000 BTUs | LP 18,000 BTUs  
 Simmer Burner Rating: 5,000 BTUs  
 Large Oven Burner Rating: 30,000 BTUs  
 Small Oven Burner Rating: 15,000 BTUs  
 Infrared Broiler Rating: 15,000 BTUs  
 Electrical Requirements: 120V, 60Hz, 15 AMPs, 1 PH  
 (Unit must be on a Non-GFI, dedicated outlet)  
 Operating Gas Pressure: NAT: 5.0" WC, LP: 10.0" WC  
 Gas Line Size: 3/4"  
 Installation Clearance: 0" Side Cabinet, 0" Back Wall

### MODEL CONFIGURATION

Eight Burners

RCS48SBV2

### BURNER CONFIGURATION

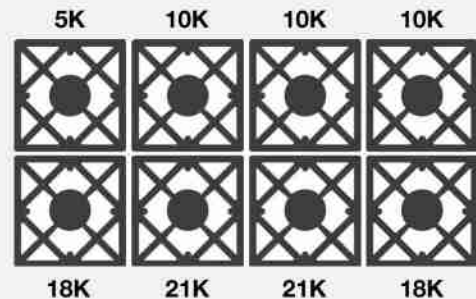

### ADDITIONAL CUSTOMIZATION OPTIONS

- 1,000 colors and finishes
- 190 knob colors
- 10 metal trims
- Available with island trim and 6" backguard only

*All specifications subject to change without notice. Visit [www.bluestarcooking.com](http://www.bluestarcooking.com) for most up to date information prior to installation or site preparation.*

*(\* LP/Propane units have maximum burner power of 18,000 BTUs)*

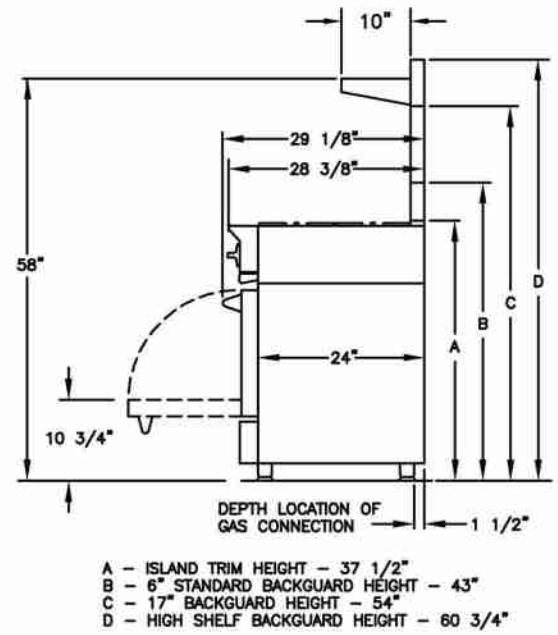
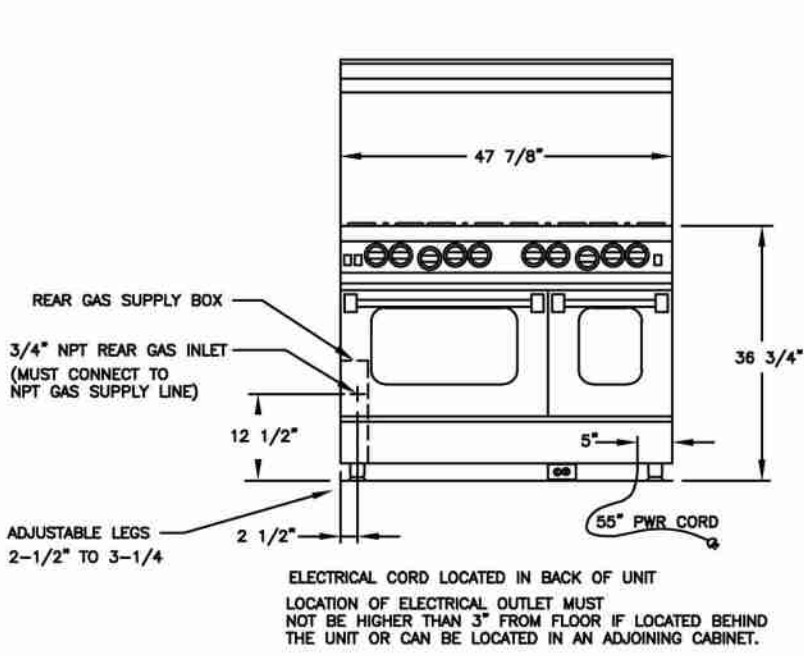

## RELATED PRODUCTS

### VENTILATION

