

PRODUCT FEATURES

- Exclusive X8™ star-shaped burner offers unmatched versatility and control on EVERY burner
- Go from extra-high sear - up to 25,000 BTUs - to an ultra-low warm of 500 BTUs on ALL burners
- Oversized True Convection oven offers even and consistent multi-rack cooking
- Fits commercial-size 18" x 26" baking sheets
- 8 cooking modes including Bake, Convection Bake, Roast, Convection Roast, Convection, Broil, Proof and Dehydrate, plus Sabbath setting and temperature probe
- Intuitive color 7" touchscreen control with Quick Start™ cooking in 3 easy touches
- Environmentally friendly, gentle 90-minute express cleaning mode + ContinuClean™ technology
- Unmatched customization - choose from 1,000+ colors and 10 metal trim finishes
- Handcrafted in Pennsylvania since 1880

SPECIFICATIONS

Overall Dimensions: 35 7/8"W x 26 1/2"D x 36"H
 Oven Interior: 29"W x 20"D x 16 5/8"H
 Bake Element Rating: 3500W (2500W Inner/1000W Outer)
 Convection Element Rating: 2800W
 Top Burner Rating (Front): Nat: 25,000 | LP: 24,000 BTUs
 Top Burner Rating (Rear): 18,000 BTUs
 Simmer Burner Rating: 500 BTUs
 Electrical Requirements: 240VAC, 60Hz, 40 AMPS, 1PH
 Unit must be on a Non-GFI, dedicated outlet
 Operating Gas Pressure: NAT 5" WC | LP 10" WC
 Gas Line Size: 3/4"
 Door Clearance: 20" from front of door

The next revolution in home cooking has arrived! Introducing the new BlueStar® Dual Fuel Range Series offering professional grade performance, handcrafted quality, stunning design, and unmatched customization options.



MODEL CONFIGURATION

6 Burners	BPDF366B (US)
	BPDF366BW (CN)

BURNER CONFIGURATION

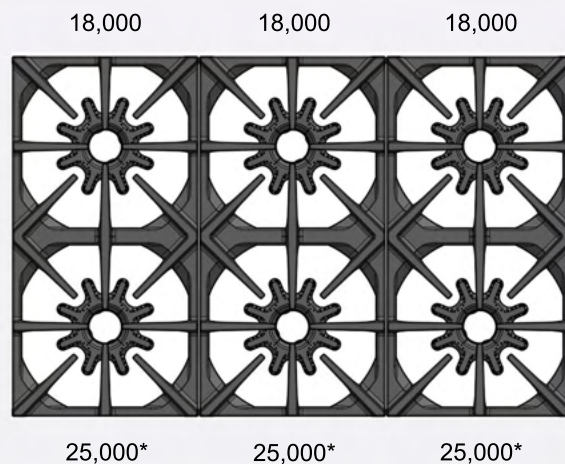

(*) 5% less output when configured for LP/Propane

ADDITIONAL CUSTOMIZATION OPTIONS

- 1,000+ Colors & Finishes
- 10 metal trim finishes
- Painted knobs in over 190 color options

All specifications subject to change with out notice

FRONT VIEW

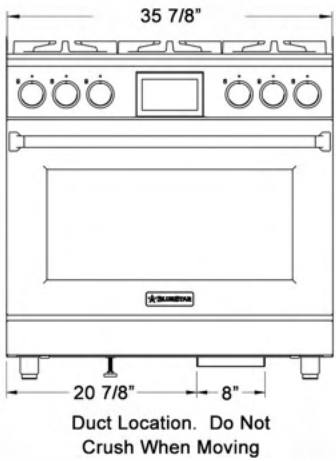

SIDE VIEW

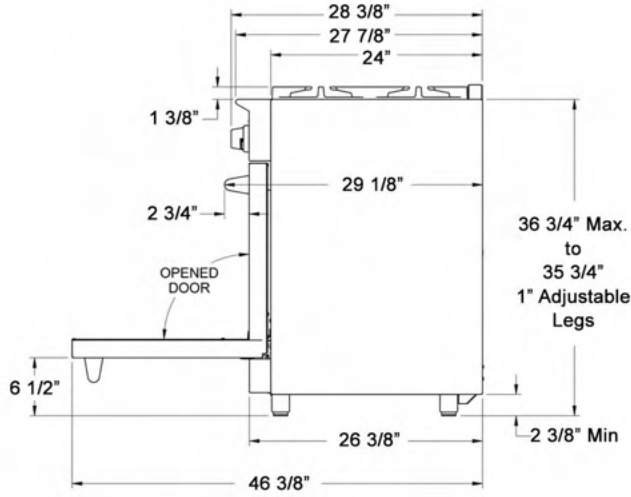

BACK VIEW

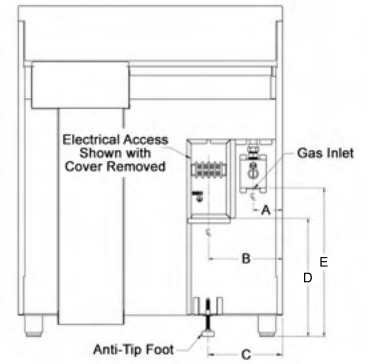

DIMENSION "A"	DIMENSION "B"	DIMENSION "C"	DIMENSION "D"	DIMENSION "E"
6 1/4"	11 5/16"	11 7/16"	13 5/8"	17 1/8"

FRONT VIEW

Ventilation hood recommended for all installations at 30" - 36" above cooktop surface

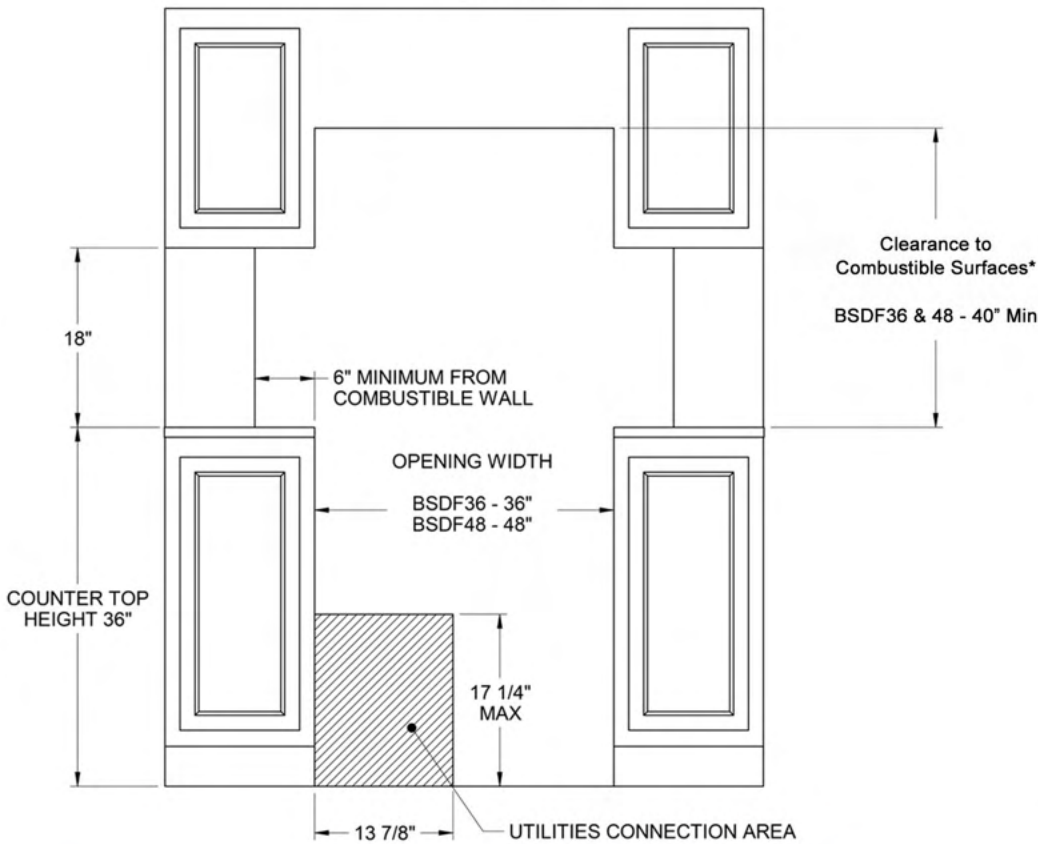

* For non-ventilation installations clearance to combustible surfaces BSDF36 & 48 is 40" min

SIDE VIEW

